

Note: Due to this being copy-pasted off the website and having all of its HTML elements removed the formatting may not always be great. My apologies about that. Other than that it should all mostly check out.

1: (Q1) The axes (normal , longitudinal and lateral ) of an aircraft will pass?

- o Zonal station 0.
- o The pressure point.
- The Centre of Gravity.

2: (Q2) What is an example of a primary flight control?

- o Slat
- Aileron
- o Spoiler

3: (Q3) The elevator is normally attached to....

- o the Rudder.
- the Horizontal Stabilizer.
- o the Dorsal fin.

4: (Q4) When an aircraft is trimmed....

- the pilot can fly loose hands.
- o all flight controls are calibrated on the 0 degrees.
- o all fuel tanks are equally filled with kerosene.

5: (Q5) Vortex generators....

- o are typically installed on low-speed piston engine powered aircraft.
- o are always installed underneath the wing.
- try to avoid the separation of the airflow on the upper surface of the wing.

6: (Q6) An elevon is a combination of....

- an Aileron and Elevator.
- o a Rudder and Elevator.
- o a V-tail and Canard.

7: (Q7) When spoilers operate in ROLL mode, what happens to the spoiler panels?

- o They all move UP the same amount.
- Only the spoiler panels are raised on the downward moving wing.
- o Only the spoiler panels are raised on the upward moving wing.

8: (Q8) The variable incidence stabilizer provides....

- long term pitch change.
- o short term pitch change.
- o Roll Control.

9: (Q9) Complete the numbered boxes.

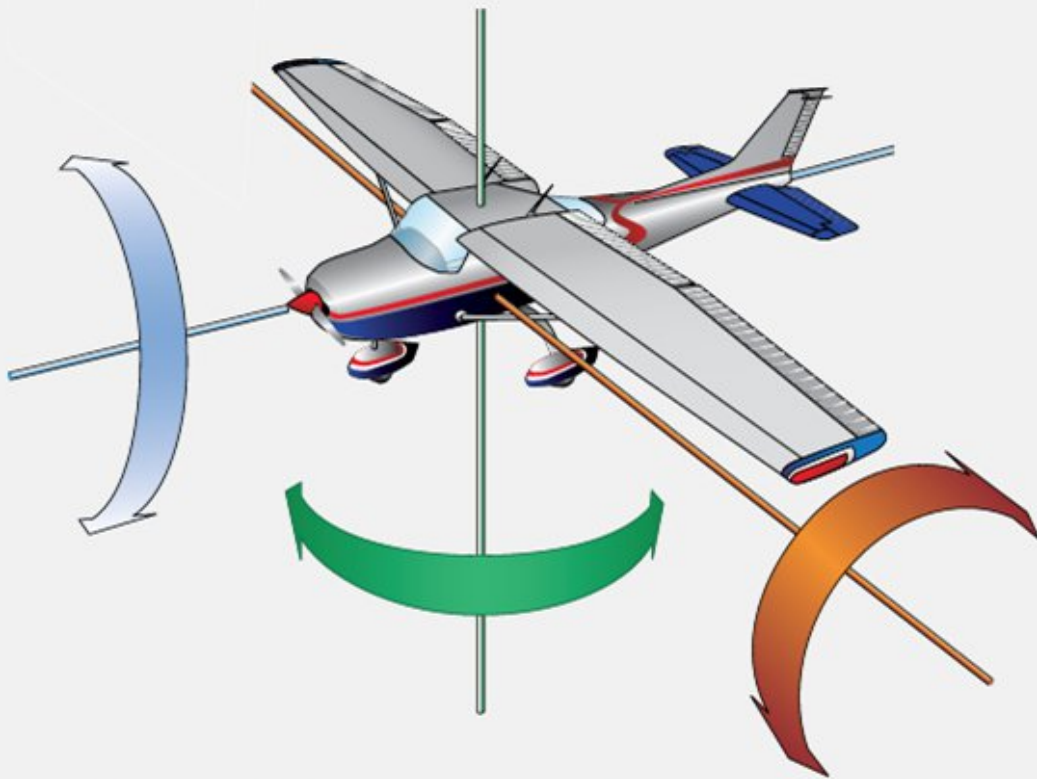

Primary Control Surface	Airplane Movement	Axes of Rotation	Type of Stability
Aileron	1	Longitudinal	Lateral
Elevator/Stabilator	2	Lateral	Longitudinal
Rudder	3	Vertical	Directional

- 1 Roll; 2 Pitch; 3 Yaw
- o 1 Yaw; 2 Roll; 3 Pitch
- o 1 Dive; 2 Climb; 3 Turn

10: (Q10) When can ground adjustable trim tabs be adjusted?

- By a maintenance engineer.
- o In flight, with a control wheel.
- o In flight using an electric motor.

11: (Q11) When a pitch input is given to an aircraft with ruddervators, what is the movement of the control surfaces on the tail?

- o They move in opposite directions.
- They will move in the same direction.
- o They don't move.

12: (Q12) What type of aerodynamic balance system is shown in the figure below?



Horn Balance

- o Aerodynamic balance panel
- o Inset Hinges

13: (Q13) Which flight control surface is shown in the figure below?



- o Ailerons.
- o Slats.
- Leading edge flaps.

14: (Q14) When using a ruddervator, what will happen when moving along the lateral axis?

- o The ruddervators will move in opposite directions
- o The rudder and aileron will move.
- The ruddervators will move in the same direction.

15: (Q15) By high speed the elevons are a combination of....

- o elevators and the trailing edge.
- o ailerons and the rudder.
- elevators and the ailerons.

16: (Q16) Where are elevons installed?

- o To each side of the aircraft on the leading edge of the wing.
- o To one side of the aircraft on the trailing edge of the wing.
- To each side of the aircraft on the trailing edge of the wing.

17: (Q30) What is the major advantage of fail-safe structural design?

- o It makes the structural construction simpler to build.
- It allows the detection of failure during the maintenance interval before it becomes catastrophic.
- o It is the cheapest way to build aircrafts.

18: (Q31) What is the difference between the 'fail-safe' and 'safe-life' principle?

- Fail-safe means that the system or part is still functional even when partially failed. Safe-life means that the part has a design operational limit and should be replaced.
- o Fail-safe means that it will not harm the aircraft when failed, while safe-life means that the part is designed to hold as long as the aircraft design life time.
- o It means the same but, fail-safe is used by the EASA, safe-life is more used by the FAA.

19: (Q32) Why do job cards mention zones?

- o The zone codes are the primary digits to find the part location in the parts catalogue.
- o These are just codes for the engineering department to analyse the damage found in certain areas during maintenance.
- They will identify a certain area of the aircraft to inspect or to locate the specific work area.

20: (Q33) What regulation is applicable for construction of large aircraft?

o Each manufacturing country applies his own regulation. This is accepted all over the world by the Chicago convention of 1964.

- All new designed large aircrafts must comply to the EASA certification specification CS-25.
- o The manufacturing of an aircraft is regulated under the EASA Part-145.

21: (Q34) What is the definition of primary structure?

o All the parts except the cabin interior.

- All the parts that support the loads of the aircraft on ground and in flight.
- o All the parts that support the loads and provide aerodynamic shape to the aircraft.

22: (Q35) What is the definition of secondary structure?

o All the parts that support the loads of the aircraft in flight.

- All the parts that improve the aerodynamic shape of the aircraft, this may include control surfaces.
- o All the parts in the cargo compartments and in the cabin interior.

23: (Q36) What is the meaning of a 'fail-safe structural design'?

o It is just a fancy expression used as commercial argument.

- o It means that in case of partial structural failure the pilot will be informed by a caution warning.
- It indicates that structural loads are shared over multiple parts.

24: (Q37) When talking about structural stresses, what do we mean with the term 'strain'?

o This term is only used when there is a permanent deformation in the material.

- A strain is a deformation or a physical change caused by a stress.
- o It means the part broke completely.

25: (Q38) What is the function of the Static dischargers?

o They will protect the communication systems against a lightning strike.

- In case of a static charge they lead the electrical energy off the aircraft.
- o They function as a communication antenna.

26: (Q39) What is the main reason of having drains in the aircraft structure?

• Collecting fluids without draining could cause fire, corrosion or causing short cuts in the electrical system.

o The humidity caused by the fluid can influence the air-conditioning system.

o To avoid the extra weight. This can overload the structure.

27: (Q40) How would you call this structural part (as indicated by the black arrow)?



- o A Pressure support. It supports the higher pressurization loads from the cabin area.
- A strut. It will mainly take compressive loads.
- o A beam. It will mainly take bending loads.

28: (Q41) What is a monocoque construction?

- o A monocoque construction is where the aircraft skin, strengthened by frames supports all the loads.
- o A monocoque construction is only made out of one material. Usually older wooden aircraft.
- A monocoque construction is where the aircraft skin supports all the loads.

29: (Q42) What is a semi-monocoque construction?

- o A semi-monocoque construction is where the aircraft frames and stringers supports all the loads.
- A semi-monocoque construction is where the aircraft frames and stringers together with the exterior skin panels support all the loads.
- o A semi-monocoque construction is made out of two materials. Usually older aircrafts with a wooden structure with canvas.

30: (Q43) Why are bulkheads used in an aircraft structure?

- They are used to give extra strength to those places where the basic structure is insufficiently strong for the loads.
- o They are used on those places where compartments needs toe sealed off from each other.
- o They are only used in the front and the back of the fuselage to hold the pressurization.

31: (Q44) Why are aft pressure bulkheads usually build as a dome?

- o The dome shape is only used because it is the cheapest to build and has no aerodynamic function in the tail.
- o The dome shape give some extra space within the cabin to give extra stowage for the galleys.
- A pressure dome is a light construction that can withstand large pressure loads.

32: (Q45) What is an 'alclad' skin?

- o it is a skin plate made out of an aluminium alloy coated on the exterior side with a thin layer of nearly pure aluminium for nice shiny effect.

- o It is the product name given by ALCO, one of the biggest manufactures of aluminium.

- It is a skin plate made out of an aluminium alloy coated on both sides with a thin layer of nearly pure aluminium for a better corrosion resistance.

33: (Q46) Where do we usually apply honeycomb structures?

- o Only on the aerodynamic fairings and internal components like floor panels.

- o Only on the interior panels, honeycomb structures do not withstand humidity.

- Floor panels, fairings, wing panels, flight control surfaces.

34: (Q47) Talking about wing structures, what do we mean with a 'cantilever monoplane'?

- o Wings constructions where the upper and lower panel supports all the loads.

- Is a design where the wing is attached to the fuselage and the wing is self-supporting.

- o Airplanes with no tail wings (stabilizers), often also called delta wings.

35: (Q48) Why do they use more and more bonded metal to metal joints on the latest aircraft? A bonded metal to metal joint is....

- o much cheaper because you don't need the rivets and labor.

- normally stronger.

- o a fast way to construct. Time is money.

36: (Q49) As a mechanic, why should you protect a bare part of fuselage skin surfaces as soon as possible?

- o You want the aircraft paint finish to be nice, it represents your professionalism.

- o It can influence the conductivity of the fuselage. This is important in case of a lightning strike.

- A painted surface is the cheapest way of corrosion prevention.

37: (Q50) When would it be necessary to check the airplane symmetry?

- o When the SRM instructs you to do so after a doubler repair on the fuselage.

- o This is a standard requirement after a heavy maintenance inspection as set in the maintenance program.

- When the AMM chapter 05 instructs you to do so after an abnormal event.

38: (Q51) In which of the following construction methods does the skin take up ALL the stresses?

- o Stressed skin construction.

- Monocoque.

- o Semi-monocoque.

39: (Q52) What type of construction is shown in the figure below?

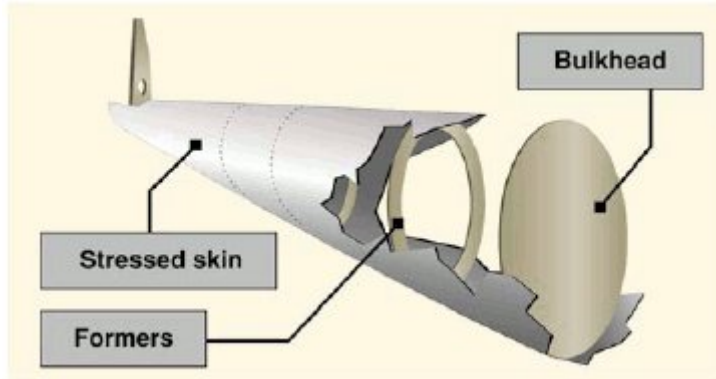

- o Cantilever construction.
- Monocoque
- o Semi-monocoque

40: (Q53) What is a cantilever wing?

- o A wing supported by struts and ties.
- A wing attached at one end only.
- o A wing attached in the middle.

41: (Q54) What is the most widely used assembly method in aircraft construction?

- Solid rivets.
- o Bonding.
- o Blind rivets.

42: (Q55) A bonded metal-to-metal joint will be:

- o Weaker than a riveted joint.
- Stronger than a riveted joint.
- o Just as strong as a riveted joint.

43: (Q56) 'DINITROL' and 'LPS-3' are what kind of surface protection?

- Water displacing fluid.
- o Paint.
- o Phosphate coating.

44: (Q57) What is the most common used surface protection for aluminium alloy?

- o Electroplating
- o Paint
- Cladding

45: (Q58) To carry out a correct alignment check, the aircraft is jacked up. What must be done next?

- o Start with the alignment check.
- o Level the datum lines in the flight position.
- Level the datum lines in the horizontal plane.

46: (Q59) What is commonly used to level an commercial aircraft?

- A plump bob and spirit level.
- o A surveyors tape measure.

o A clinometer.

47: (Q60) Buckled skin and torn rivets are indicators of:

- Structural failure.
- o Bad construction.
- o Deviations in aircraft a-symmetry

48: (Q61) What kind of structural joint is represented in this picture?



- o This is a lap joint, only used in pressurized areas.
- This is a butt joint, used to join different fuselage sections.
- o This is a section joint, only used in unpressurized areas.

49: (Q62) What kind of structural joint is represented in this picture?

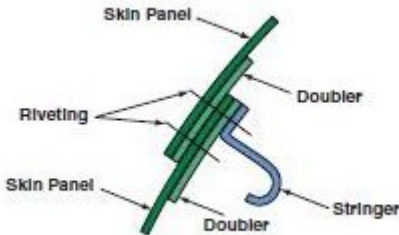

- o This is called an overlapping joint.
- This is called a lap joint.
- o This is called a butt joint.

50: (Q63) On a modern aircraft, which zones are not pressurized?

- o The 3 wheel wells, tail section and the main avionics compartment.
- o The 3 wheel wells, tail section and forward cargo.
- The 3 wheel wells, radome, wing and tail section.

51: (Q64) Why are there so many structural reinforcements around the landing gear attachments?

o The main reason for these reinforcements is to support the vibrations while running over taxi ways. It is financially not possible to build taxi ways so smooth and even as the runways.

o You will find only a lot of structural reinforcements on aircraft with retractable gears. This is to support the big torque forces during gear retraction.

• The landing gear loads are the largest on the aircraft and it requires a lot of reinforcement to transfer these loads into the aircraft.

52: (Q65) You will find this panel from this picture in the cargo compartment. What is the name and purpose of this panel?

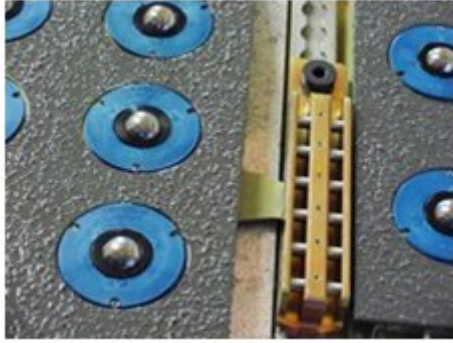

- A ball mat panel. They are installed in front of the cargo-door and allow an omnidirectional movement of the pallet.
  - o Lifting ball panels. They provide a small space between the floor and the pallet to allow air ventilation. The perforated pallets are used for transport of fresh vegetables, flowers, etc.
  - o Sliding carpet. Typical for older aircraft where the pallet loading is done manually.

53: (Q66) What is a plug type door?

- o It is a passenger door that slides upwards into the interior ceiling when opened. (typical DC 10)
- o It is a door that is closed from inside to outwards, that way it pushes against its door stop. It needs a special locking because the door can be forced open when pressurized.
  - It is a door that is closed from inside to outwards, that way it pushes against its door stops and is impossible to force open when the aircraft is pressurized.

54: (Q67) What is a non-plug-type door?

- o It is a door only used for non-pressurized areas.
  - Is a door that is closed from the outside. All the pressurization loads are carried by the hinges and the closing mechanism.
- o It is an outside type of door that is only used for very large doors such as cargo doors.

55: (Q68) Why does a door pressurization seal have small holes at equal intervals?

- Via these holes the cabin pressure can enter the seal. The press difference will inflate the seal and this will provide a perfect sealing against the door frame structure.
  - o These holes will keep the seal flexible and so increase its life time.
  - o These are ventilation holes. When descending from high altitudes (dry air) to low altitude (humid air) a lot of condensation will come between the door and the door frame. (icing danger)

56: (Q69) How would you describe the layers of a cockpit window?

- The window consists of an inner glass layer which is the main structural element, a synthetic middle layer as structural backup, a heating element and a hard glass outer layer.
  - o The window consists of an inner and an outer glass layer. In between there is an electrical heating element.
  - o The window consists of an air heated and ventilated inner glass layer, a synthetic middle layer, a hard glass outer layer which is also the main structural part.

57: (Q70) What is a dummy window?

- It is a metal plug plate to cover the hole where a window is removed.
  - o It is the most inner cabin-window, and provides an acoustic damping.
  - o This window has a protection layer against passenger abuse.

58: (Q71) Where would you find rapid depressurization panels?

- The wall linings of the cargo hold.
- o The bottom of the passenger cabin side walls.
- o In the pressure bulkheads.

59: (Q72) Which of the following compartments is usually unpressurized?

- o Avionics compartment.
- Rear fuselage area.
- o Cargo compartment.

60: (Q73) Why are non-magnetic bolts used on the front windshields?

- So they don't interfere with the standby compass.
- o They are less likely to be hit by lightning.
- o They are stronger than other bolts.

61: (Q74) When an aircraft is transporting dangerous goods ....

- there will be special flight conditions.
- o there will be separated goods in special containers.
- o there is no need for special precautions.

62: (Q75) The most common used floor material for passenger compartment floors are ....

- o aluminium.
- composite material.
- o aluminium reinforced and steel bars.

63: (Q76) How would you describe this type of wing structure?

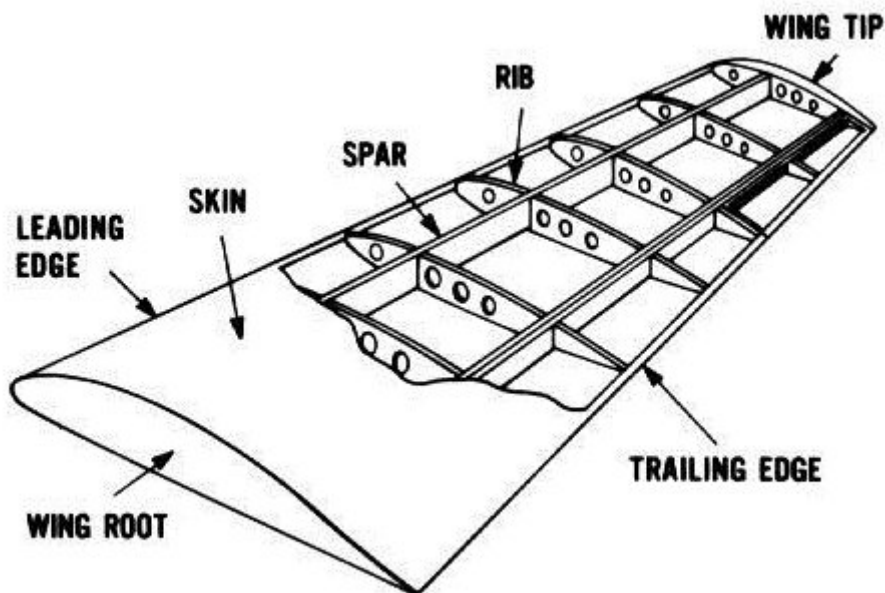

- A cantilever mono-spar wing.

- o A semi-monocoque wing.
- o A truss type mono-beam wing,

64: (Q77) What kind of loads are mostly working on the wing skin panels during flight?

- o The upper wing panel bears tension loads, the lower panel receives compression loads.
- o Both the upper and lower wing panel and receive compression loads.
- The upper wing panel bears compression loads, the lower panel receives tension loads.

65: (Q78) Why do we find false spars or reinforcement ribs on some locations in the wing ?

- False spars and reinforcement can be found everywhere on the wing where extra support is needed for landing gear fittings.
- o The main purpose of false spars and reinforcement ribs is to prevent slushing of the fuel to the wing tip when the aircraft takes a turn.
- o You will find this only near the landing gear beam attachment. The main purpose is to support the important loads of the aircraft resting on its gears.

66: (Q79) Concerning the spoilers, which statement is correct?

- o Flight spoilers are used to increase lift.
- Flight spoilers create drag and so can have a roll function or a speed brake function.
- o Aircraft spoilers have the same function as on a car, they improve the aerodynamics.

67: (Q80) On modern aircraft, where can the fuel be stored?

- o In the engine pylons.
- o In the cargo area.
- In the wings, in the centre-tank and stabilizer.

68: (Q81) How can we prevent the fuel from leaking.

- o The fuel is always stored inside bladder tanks, installed inside the wing structure.
- All the structural parts like rivets, spars, beams are sealed with a sealant to keep the tank fuel tight.
- o All the fuel tanks are inside coated with a layer of rubber which keep the fuel tank tight.

69: (Q82) What is the function of false ribs or nose ribs?

- They shape the leading edge of the wing.
- o They shape the wing surface but do not add to the structural strength of the wing.
- o They provide support for the mounting of the landing gear.

70: (Q83) The lower wing surface is made of AL-2024 to withstand ...

- tension loads.
- o shear loads.
- o compression loads.

71: (Q84) The upper wing surface is made of AL-7075 to withstand ....

- compression loads.
- o tension loads.
- o shear loads.

72: (Q85) To withstand tension loads, the lower wing surface is made of ....

- AL-2024.

- o AL-7075.
- o AL-2016.

73: (Q86) When there is an extra wing spar installed for the landing gear, this is called the .....

- false spar.
- o afts spar.
- o mid spar.

74: (Q87) To withstand compression loads, the upper wing surface is made of ....

- o AL-6025.
- o AL-2024.
- AL-7075.

75: (Q88) What is the most critical part of a wing as far as the production of lift is concerned?

- o Top and bottom side of the wing.
- o Trailing edge and bottom side of the wing.
- Front end or leading edge.

76: (Q89) Integral fuel tanks are sealed by:

- o Rubber bladder tanks.
- Using sealant on all seams and rivets.
- o Rubber O-rings and gaskets.

77: (Q90) Access into an integral fuel tank by:

- Manhole covers on the lower wing surface.
- o Manhole covers on the upper wing surface.
- o There is no access into integral tanks they are sealed units and are removed as a whole.

78: (Q91) What are rigid fuel tanks usually made of?

- o Stainless steel
- o Plastic
- Light alloy

79: (Q92) What can be an advantage of a T-tail configuration?

- The horizontal surfaces are out of a potential turbulent air stream created by the main wings or the engines attached to the wing.
- o It creates the possibility to have rear mounted engines.
- o The stabilizer needs a smaller surface, reducing drag.

80: (Q93) How is a vertical stabilizer build?

- A vertical torque box made out of two main spars and ribs, a leading and trailing edge, a dorsal fin. A rudder panel is attached to the aft spar fittings.
- o On modern airplanes the vertical stabilizers is always of the mono-spar principle. The spar is always aft since it has to carry the rudder.
- o Mostly it is built like the fuselage structure principle. Beams and stringers covered with skin panels. A monocoque structure.

81: (Q94) What do we mean when we talk about empennage?

- The empennage is the assembly of the horizontal and vertical control surfaces and stabilizers.
- o Sometimes also referred to as Dorsal Fin
- o The empennage is the complete mid and aft section of the aircraft.

82: (Q95) Radio antenna and HF equipment can typically be found on or in

- Vertical stabilizer.
- o Horizontal stabilizer.
- o Avionics bay.

83: (Q96) The section of the aircraft which supports the horizontal and vertical stabilizers is called:

- o Keel beam
- o Tail plane
- Empennage

84: (Q97) What kind of stability provides the horizontal stabilizer?

- Longitudinal.
- o Directional.
- o Lateral.

85: (Q98) What kind of stability provides the vertical stabilizer?

- o Lateral.
- o Longitudinal.
- Directional.

86: (Q99) On the vertical stabilizer, which fittings take up the most of the lateral loads?

- Aft fittings.
- o Forward fittings.
- o Top fittings.

87: (Q100) How is the vertical stabilizer attached to the fuselage?

- o Bonded
- Bolted
- o Riveted

88: (Q101) Where are the pivot points of the trimmable horizontal stabilizer located?

- o The trimmable horizontal stabilizer does not have pivot points.
- At the rear of the tail cone-structure.
- o At the front of the tail cone-structure.

89: (Q102) Where are static dischargers normally installed on flight controls?

- Trailing edge.
- o Leading edge.
- o Nose edge.

90: (Q103) Which flight controls need to be balanced?

- Aileron and tabs, rudder and tabs, elevator and tabs.
- o Flaps.
- o Flight spoilers.

91: (Q104) On what location do we find the dynamic balance weight on a control surface?

- o On the hinge point axis line
- In front of the hinge point axis.
- o Aft of the hinge point axis line.

92: (Q105) When we talk about balance tabs and balance weights, is there a difference?

- o No, it is a different name used by the two biggest manufactures.
- Yes, balance weights are always installed to have a static balance of the control panel around his hinge points. Balance tabs is a construction that will provide an aerodynamic force assistance when the control panels move.
- o Yes, ones the balancing is done via a separate panel, the other method is used by added weights on the control panel.

93: (Q106) To eliminate flutter by high speed flight, control surfaces should be....

- balanced.
- o locked by the pilot.
- o extended.

94: (Q107) The slats are supported by:

- o Hinges.
- Curved steel tracks.
- o Straight tracks.

95: (Q108) Elevator range of movement is:

- o Smaller in the up-movement.
- Larger in the up movement.
- o The same up and down.

96: (Q109) Krueger flaps are a type of:

- o Trailing edge high lift device.
- o Lift dumping device.
- Leading edge high lift device.

97: (Q110) Which of the following is used to aerodynamically balance a control surface?

- Balance panel.
- o Balance weight.
- o Anti-servo tab.

98: (Q111) Flutter can be reduced by using?

- o A horn balance.
- Mass balancing.
- o Trim balance tabs.

99: (Q112) Why are flight controls mass balanced?

- To reduce flutter.
- o To ensure aircraft centre of gravity remains within limits.
- o To reduce the force required to move them in flight.

100: (Q113) What type of aircraft does not need mass balancing?

- o Aircraft equipped with aerodynamic balance tabs.
- Aircraft controlled with fly-by-wire.
- o Aircraft operated with control cables.

101: (Q114) How can 'FLUTTER' of the flight control surfaces be reduced?

- o By aerodynamic balancing.
- o By using trim tabs.
- By mass balancing.

102: (Q115) What is used to reduce the possibility of flutter of control surfaces?

- o Dynamic balance.
- Mass balance.
- o Aerodynamic balance.

103: (Q116) Why is the leading edge of the nose cowl of an engine made out of metal?

- o Resistance for bird strike impacts. Metal is stronger and the risk is potential.
- o Cost, such a round bended shape in composite is too expensive.
- The nose cowl leading edge needs to be anti-iced with hot air.

104: (Q117) What should be the general function of a fire seal?

- Prevent entry combustible fluids in dangerous areas.
- o Drain fluid leaks. Contain hot air gasses within the section.
- o Ensures propagation of the fire to other compartments where it can be extinguished.

105: (Q118) What materials are usually used to make a fireproof compartment?

- o Stainless steel, titanium or 7075-T3 heat resistant aluminium.
- Stainless steel, titanium or thermoplastics.
- o Stainless steel, titanium or Kevlar composites.

106: (Q119) What is the purpose of a blow-out panel (inside a nacelle)?

- o To allow the air-pressure to equalize if the pressure inside the nacelle becomes lower than outside.
- o To allow pressure inside the nacelle to escape in case of fire.
- To allow excess pressure to escape from the nacelle in case of a bleed duct rupture.

107: (Q120) Titanium and steel are used in which areas of the nacelle?

- o The intake and exhaust.
- o Fan cowl doors.
- Combustion chamber and exhaust.

108: (Q121) Where on a nacelle would you find acoustic panels?

- o Intake and turbine cowls.
- o Fan cowls and pylon.
- Intake and exhaust.

109: (Q122) Which components are part of the firewall?

- o Exhaust cowling.

- o Hinged cowlings but only when open.
- Hinged cowlings.

110: (Q123) The purpose of a fire seal is to prevent....

- o fire reaching the components contained inside the firewalls.
- o fire reaching the passenger cabin.
- hot air from the engine core circulating in the fan case area.

111: (Q124) Which of the following materials is NOT used for firewalls?

- o Titanium.
- o Thermoplastics.
- Aluminium alloy.

112: (Q237) When you replace an aircraft battery:

- o appropriate lifting devices are not necessary.
- o after battery replacement, no testing or maintenance is required.
- use of applicable aircraft manuals is essential.

113: (Q238) An aircraft battery charger:

- is charging one particular battery.
- o charges all batteries in the aircraft.
- o stops charging if there is a AC supply under-voltage (134V)

114: (Q239) A Lead-acid aircraft battery

- o has 12 cells, 1,2 VDC each.
- o can provide 28 VDC to an electrical aircraft system.
- has a nominal voltage of 24 VDC.

115: (Q240) A Ni-cd aircraft battery thermal run away:

- can be stopped by removing the charging source.
- o is the result of a battery-charger over-temperature.
- o can result in a frozen battery.

116: (Q241) A Ni-cd aircraft battery:

- o has a nominal voltage of 24 VAC.
- o has a nominal voltage of 28 VDC.
- has 20 cells, 1,2V each.

117: (Q242) Ni-cd aircraft batteries:

- o can be stored with other types of batteries.
- o must be stored outside in a well ventilated area.
- may not be stored in the same area as Lead-acid batteries.

118: (Q243) A transformer rectifier unit converts....

- o 28 VAC into 115 VDC.
- 115 VAC into 28 VDC.
- o 115 VAC into 28 VAC.

119: (Q244) An aircraft battery:

- o provides power for the transformer rectifier unit (TRU).
- provides power for apu starting.
- o provides direct power for an emergency AC battery bus.

120: (Q245) The DC bus-bars are normally fed by:

- o Main aircraft batteries only.
- Transformer rectifier units.
- o DC generators only.

121: (Q246) The three stages of an AC generator are PMG, ....

- o GCU and main alternator.
- exciter and main alternator.
- o exciter and GCU.

122: (Q247) What is the standard output of an aircraft AC generator?

- o 3-phase, 400Hz, 115/200 VDC.
- 3-phase, 400Hz, 115/200 VAC.
- o single phase, 400Hz, 115/200 VDC.

123: (Q248) The APU generator:

- o also supplies hydraulic power.
- does not have a constant speed drive.
- o only supplies electrical power when the aircraft is on the ground.

124: (Q249) Emergency electrical power can be supplied by an air driven generator, ....

- o integrated drive generator, main battery.
- hydraulic motor generator, main battery.
- o hydraulic motor generator, generator control unit.

125: (Q250) The hydraulic motor generator (HMG):

- o can only be re-stowed when the aircraft is on the ground.
- provides electrical power when an engine generator fails.
- o supplies hydraulic power in case of an engine failure.

126: (Q251) The air driven generator:

- o supplies electrical power when the aircraft is on the ground.
- can only be re-stowed when the aircraft is on the ground.
- o provides electrical power in normal flight.

127: (Q252) The generator control unit (GCU) protects against....

- o bus under-current, over-voltage.
- over-voltage, under-frequency.
- o under-current, over-frequency.

128: (Q253) Differential protection (DP) protects....

- when there is a current decrease of more than 25 Amps.
- o when there is an open phase.

o against under-current, over-frequency.

129: (Q254) The voltage regulation from the generator of an APU is controlled by....

- o the speed control unit.
- a generator control unit.
- o the constant speed drive.

130: (Q255) When electrical load shedding occurs, electrical power is....

- o always available to the galley.
- o available to the utility busses.
- available to critical and essential equipment.

131: (Q256) A static inverter transforms....

- o 28 VAC to 28 VDC.
- 28 VDC to 115 VAC.
- o 115 VAC to 28 VDC.

132: (Q257) A transformer transforms....

- o 28 VAC to 28 VDC.
- 115 VAC to 28 VAC.
- o 28 VDC to 115 VAC.

133: (Q258) A transformer rectifier unit (TRU) converts....

- o 115 VDC into relatively smooth 28 VAC power.
- 115 VAC into relatively smooth 28 VDC power.
- o 28 VDC into relatively smooth 115 VAC power.

134: (Q259) A circuit breaker:

- o may never be reset.
- should be allowed to cool before resetting.
- o must be replaced after a circuit breaker trip.

135: (Q260) When a circuit breaker trips:

- o the circuit breaker should be reset as soon as possible.
- a white collar is exposed.
- o a technician must replace the circuit breaker.

136: (Q261) A remote control circuit breaker:

- o must be replaced after a circuit breaker trip.
- allows the location in other places besides the cockpit.
- o must be reset as soon as possible.

137: (Q262) External electrical power

- supplies the aircraft with 115 VAC/400 Hz.
- o can be applied in flight.
- o can be connected in the hangar with engines running.

138: (Q263) The ground handling bus:

- is powered on the ground by the APU or external power.
- o supplies the main AC busses.
- o has an extra external power supply available to power all handling busses.

139: (Q264) The electrolyte in a NiCd battery is?

- o Acid based.
- o Lithium based.
- Alkaline based.

140: (Q265) What is the nominal voltage of a NiCad battery cell?

- o 24 volts.
- o 2 volts.
- 1.2 volts.

141: (Q266) Which is the most efficient way of charging a battery?

- o Both slow and fast are equally efficient
- o Fast
- Slow

142: (Q267) Which type of battery can experience cell reversal and how can it be prevented?

- NiCad battery. Prevented by never fully discharging the battery.
- o NiCad battery. Prevented by always fully discharging the battery.
- o Lead-acid battery. Prevented by fast charging battery.

143: (Q268) What happens at the end of the charge of a NiCad battery?

- o The battery heats up.
- The cell voltage drops.
- o CO<sub>2</sub> is generated,

144: (Q269) What product does the sump jar contain in the vent line of a lead-acid battery installation?

- o Distilled water.
- o Boric acid.
- Bicarbonate of soda and water.

145: (Q270) What is the dis-advantage of series wound generators?

- o When the aircraft electrical load increases, the output voltage remains the same.
- When the aircraft electrical load increases, the output voltage increases.
- o When the aircraft electrical load increases, the output current increases.

146: (Q271) What is the purpose of a rectifier?

- Convert the AC output to DC.
- o Control the output voltage of a parallel wound generator.
- o Convert the DC output into AC.

147: (Q272) What determines the amount of induced voltage?

- The speed at which the conductor moves through the magnetic field.
- o The length of the field frame.
- o The diameter of the conductor.

148: (Q273) How do you call the component that completes the magnetic circuit between the poles in a DC generator?

- The brushes.
- The yoke.
- The armature.

149: (Q274) The output of a single coil generator is

- a saw foot.
- a flat line.
- a sine-wave.

150: (Q275) What type of voltage regulator is shown in the figure below?

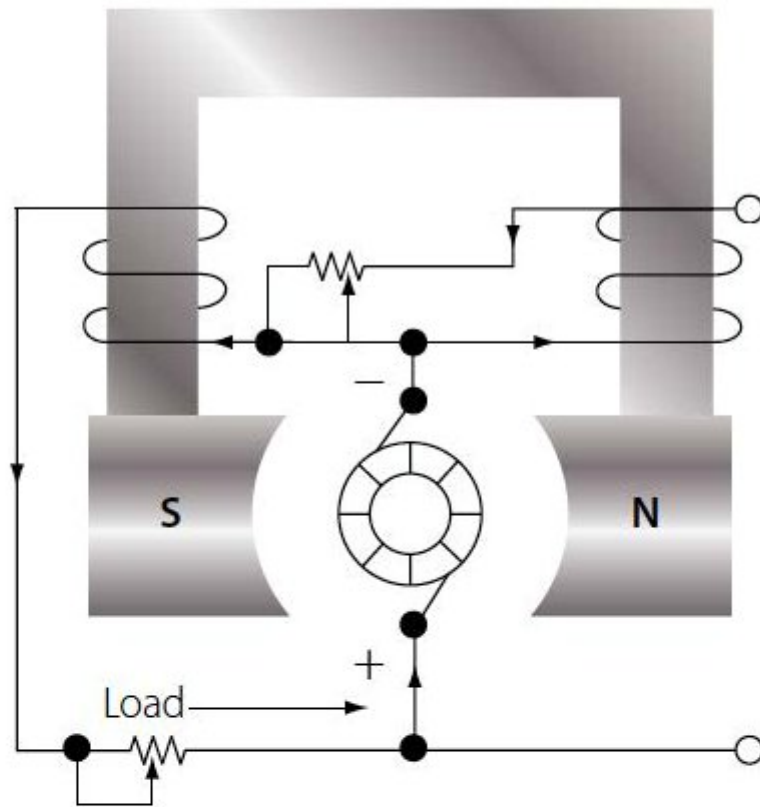

(A)

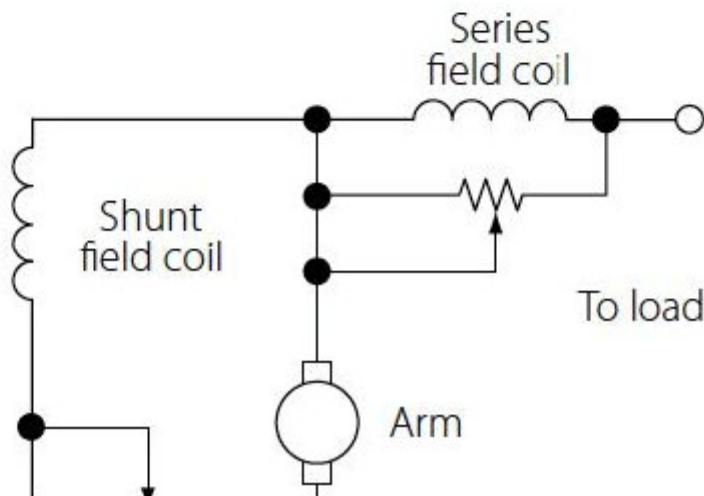

- Compound wound generator.
- o Series wound generator.
- o Parallel wound generator.

151: (Q276) What type of generator / alternator is used in a variable speed constant frequency system?

- DC alternator.

- o Brushless alternator.
- o DC generator.

152: (Q277) Which of the following systems does not use a constant speed drive?

- APU alternator.
- o Engine driven alternator.
- o Integrated drive generator (IDG)

153: (Q278) What is the output speed of a constant speed drive?

- o Variable speed depending on engine speed.
- o 12000rpm
- 6000rpm

154: (Q279) If the over-speed protection circuit in a CSD (Constant Speed Drive) has activated, reset is...

- o possible from the flight deck.
- only possible in the workshop.
- o possible during Line Maintenance.

155: (Q280) The output sine waves of a 3-phase alternator will be separated by:

- o 60 degrees
- 120 degrees
- o 90 degrees

156: (Q281) In which type of unit can a permanent magnet generator (PMG) be found?

- Brushless AC alternator.
- o DC generator.
- o DC alternator.

157: (Q282) Which of the following statements about the ram air turbine is false?

- o The RAT can be deployed manually.
- o The RAT can sometimes also supply hydraulic power.
- The RAT can deploy automatically on the ground.

158: (Q283) In a constant speed motor generator, what powers the generator?

- o An electric motor powered by the RAT generator.
- o An electric motor powered by the battery.
- A hydraulic motor powered by a hydraulic pump driven by the RAT.

159: (Q284) What powers the hydraulic motor generator (HMG)?

- o RAT hydraulic pump.
- o Hydraulic hand pump.
- Main hydraulic system.

160: (Q285) When will the hydraulic motor generator (HMG) supply power?

- o Manually, when the pilot switches it on after both main AC buses lose power.
- Automatically when both main AC buses lose power.
- o Automatically when the main battery is discharged.

161: (Q286) The ram air turbine will supply....

- single phase AC power.
- o DC power.
- o three phase DC power.

162: (Q287) What is the function of the flyweight governor (installed in the RAT)?

- o It controls the speed of the constant speed motor generator (CSM/G).
- It controls the speed of the ram air turbine.
- o It controls the output voltage of the hydraulic motor generator (HMG).

163: (Q288) How is voltage regulation achieved on DC generators? By changing the....

- o generator speed.
- o field voltage.
- field current.

164: (Q289) Which of the following is NOT part of a three-unit voltage regulator?

- o Reverse current relay.
- Open phase protection.
- o Current limiter.

165: (Q290) What type of voltage regulator is shown in the figure below?

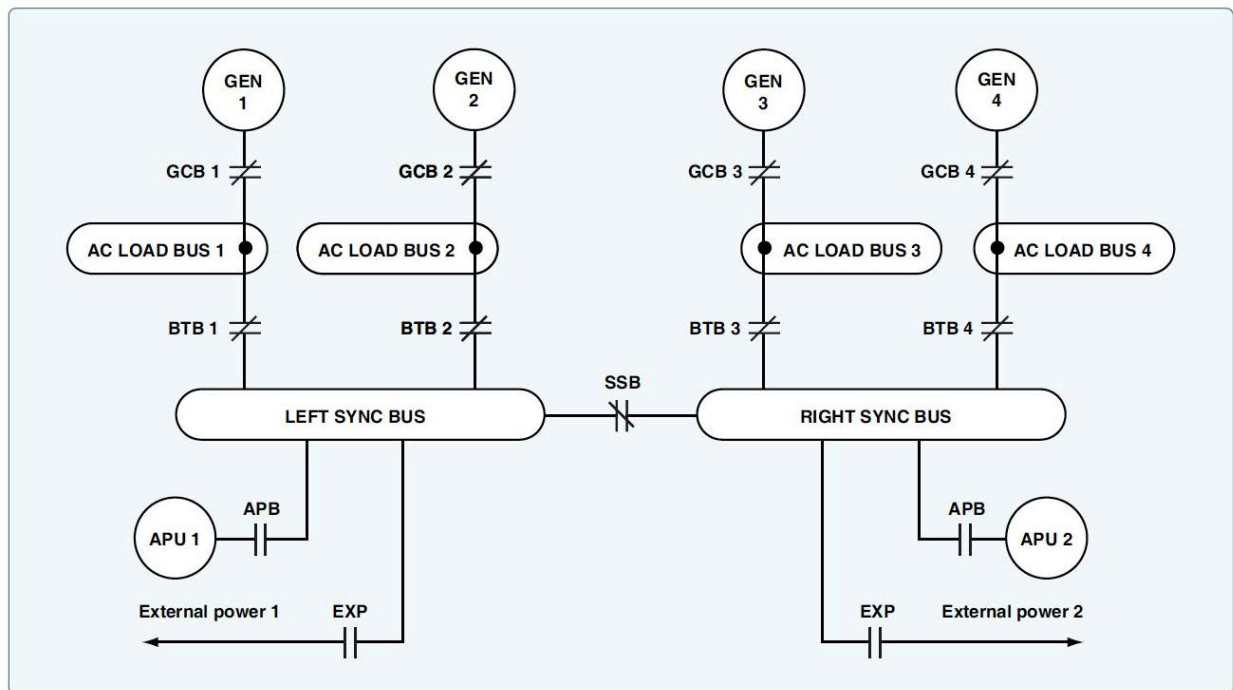

- Three-unit voltage regulator.
- o Carbon pile voltage regulator.
- o Reverse current delay.

166: (Q291) In a parallel bus configuration the generators will:

- o Divide the load, with the strongest generators taking the biggest load.
- Share the load equally among them.

o Each supply their own AC bus.

167: (Q292) Emergency lighting is part of which service?

- o Essential.
- Vital.
- o Ground.

168: (Q293) What type of bus is show in the figure below?

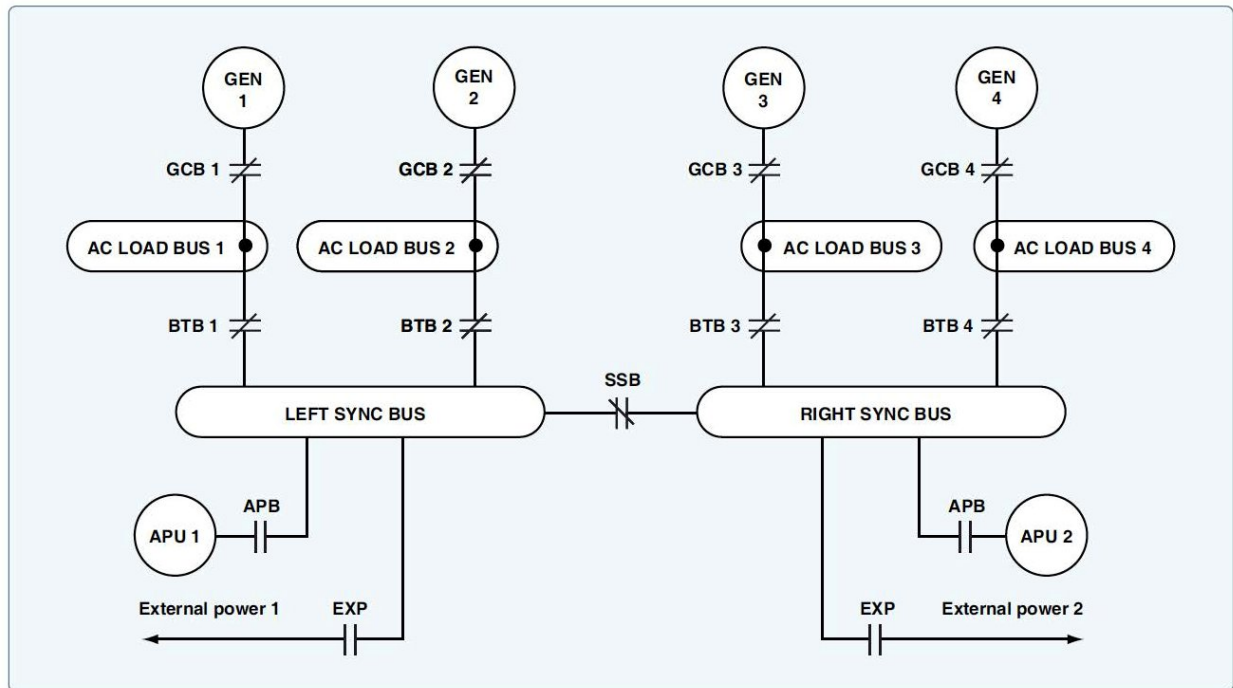

- o Mergency bus
- o Parrallel bus
- Split Parallel Bus

169: (Q294) What is the primary function of a current transformer in an aircraft?

- o Step-up the current in a circuit.
- o Measure voltage in an electrical circuit.
- Measure current in an electrical circuit.

170: (Q295) Which of the following statements about current transformers is true?

- o Current transformers always have a square transformer core.
- o The primary winding should never be left open when in operation.
- The secondary winding should never be left open when in operation.

171: (Q296) Which formula represents the transformer ratio?

- o  $V_2 / N_2 = V_1 / N_1$
- o  $V_2 \times V_1 = N_2 \times N_1$
- $V_2 / V_1 = N_2 / N_1$

172: (Q297) Transformer rectifiers are used for:

- Converting DC into AC.
- Boosting the output voltage from 28V to 110V.
- Converting AC into DC.

173: (Q298) What provides overheat warning in a transformer rectifier unit?

- Thermal switch.
- Voltage sensor.
- Thermocouple.

174: (Q299) What type of transformer is shown in the figure below?

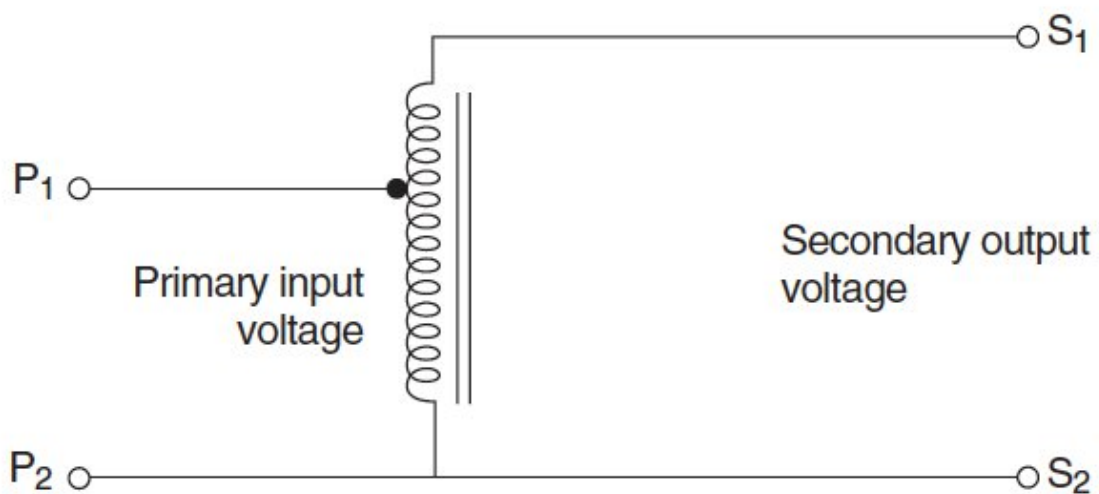

Transformer rectifier.

- Autotransformer
- Current transformer

175: (Q300) Which of the following circuit breakers CANNOT be reset while the fault exists?

- Automatic reset circuit breaker.
- Electromagnetic circuit breakers.
- Trip free circuit breaker.

176: (Q301) Where in the circuit would a fuse be installed?

- As close to the power source as possible.
- As close to the unit to be protected as much as possible.
- Where access to replace the fuse is easiest.

177: (Q302) In the differential protections circuit in the figure below, what type of transformers would be TRANSFO 1 and TRANSFO 2?

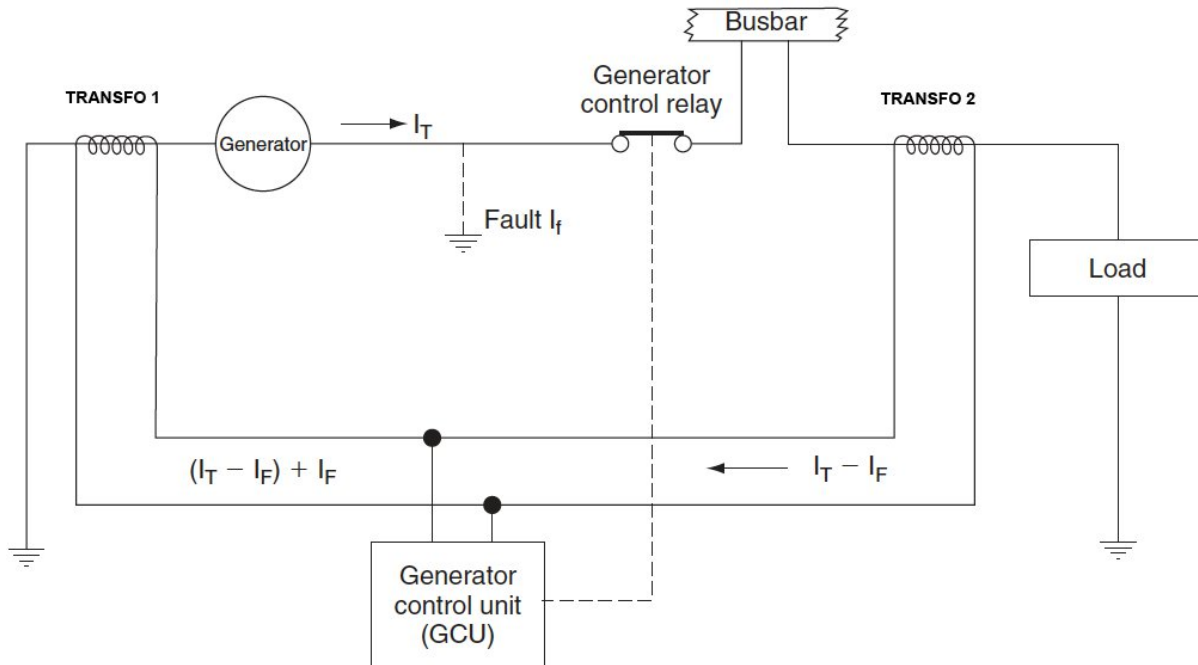

- o TRANSFO 1 is a current transformer, TRANSFO 2 is a voltage transformer
- o Both are voltage transformers
- Both are current transformers

178: (Q303) On a large commercial aircraft, which bus will be powered as soon as external power is connected?

- o The external power bus.
- o Battery bus.
- The ground handling bus.

179: (Q304) What is 'no breaks power transfer'?

- Power supply is transferred from one source to another without interrupting the supply.
- o Power supply remains with the same source even though power transfer to another source has been selected.
- o Power supply is transferred from one source to another while bypassing the circuit breakers.

180: (Q305) When connecting external power, what prevents the application of reverse polarity to a DC powered aircraft?

- A reverse polarity diode.
- o A reverse current switch.
- o An irreversible external power connector (fool proof).

181: (Q379) In flight controls, what do we mean with a 'direct cable control system'?

- o a direct cable connection between the control column and the flight control computer.
- o a direct cable connection between the control column and the hydraulic control valve.
- a cable connection between the control column and the control surface.

182: (Q380) What logic would you expect from an hydraulic operated flight control system in an aircraft with a fly by wire concept.

- o Control column input - steel wire - computer - electrical wire - hydraulic actuator - control surface.
- Control column input - electrical wire - hydraulic actuator - control surface.
- o Control column input - control valve - steel wire - hydraulic actuator - control surface.

183: (Q381) Torque tubes are used on many places in flight control systems. How would you describe them and what kind of forces do they transmit? Torque tubes are ....

- hollow metal tubes used to transmit torsional force to the device being controlled.
- o hollow metal tubes used to transmit push-pull forces to the device being controlled.
- o full metal tubes used to transmit bending forces to the device being controlled.

184: (Q382) On large aircraft, what will influence the required force to move a primary flight control surface?

- o The control force required will decreases with the size of the control surface.
- The control force required will increases with the speed and with deflection angle.
- o The control force required will increases with altitude.

185: (Q383) How would you describe the term 'hydraulic servo system' in a powered flying control system?

- Is a system where a small input initiates a large power output, which is transmitted by a hydraulic piston-actuator to move for example a control surface.
- o Is a system used where a power chamber gives pressure in a line, but the pressure never flows directly into a return line. (Brake systems)
- o Is a system where a small hydraulic input will transmitted a feedback signal.

186: (Q384) What kind of rod is installed in large aeroplane flight control systems?

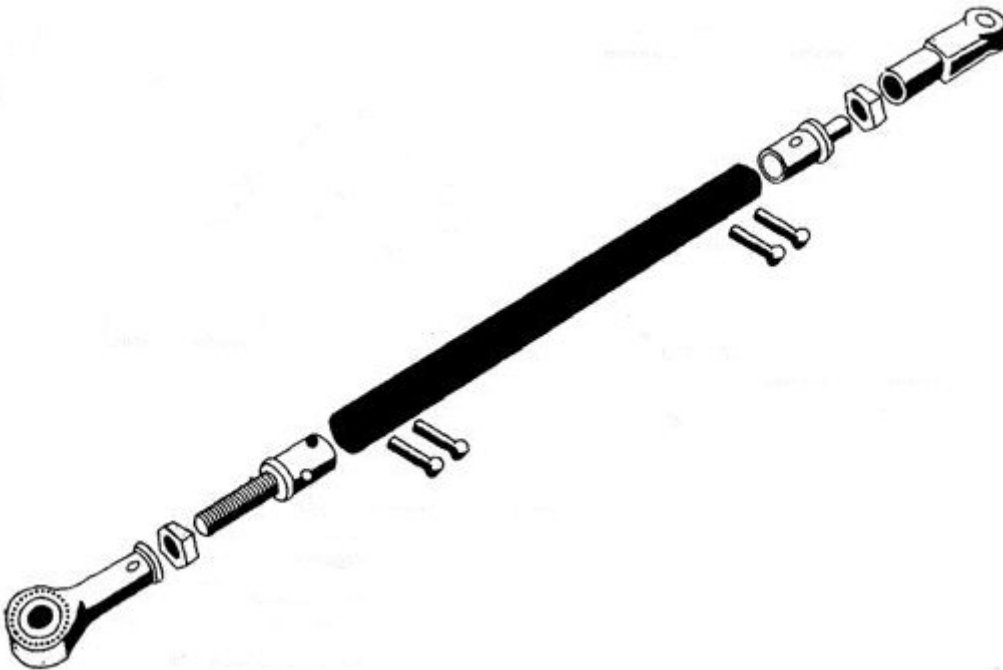

- push-pull rod.

- o tension rod.
- o compression rod.

187: (Q385) On large aircraft what is the function of the flap?

- o They increase the wing surface, this will provide additional slow down the aircraft.
- o They change the camber of the wing, this will require less thrust on low altitudes.
- They will increase the wing surface and camber and so create more lift.

188: (Q386) Why is it so dangerous to have a flap asymmetry condition?

- o The flap asymmetry induce a dangerously strong twist effect in the torque tubes.
- The flap asymmetry can create a wing roll effect out of range of aileron recovery possibilities.
- o A flap asymmetry causes so much drag on one side that the rudder is out of compensation range.

189: (Q387) On most aircraft, what will be the required input signals to have an auto extension of the ground spoiler system?

- o Radio altitude less than 10 feet - all throttles in idle or reverse - speed within normal range.
- On ground signal - wheel speed - all throttles in idle or reverse - speed within normal range.
- o On ground signal - wheel speed - min. one throttle in idle - ground speed within normal range.

190: (Q388) What kind of flap configuration is used here?

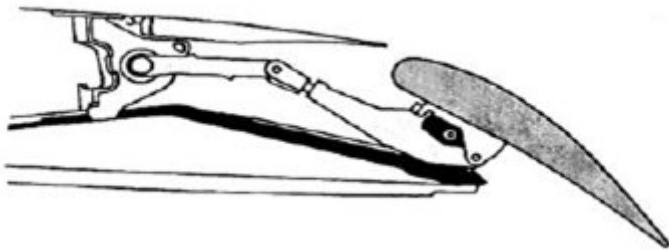

- o The hinged flap configuration.
- Track and carriage configuration.
- o The fowler system.

191: (Q389) What logic would you expect from an hydraulic operated flight control system on an aircraft which would not be considered fly by wire.

- o Control column input - electrical wire - command computer - hydraulic actuator - control surface.
- o Control column input - steel cable - monitoring computer - hydraulic actuator - control surface.
- Control column input - steel cable - hydraulic control valve - hydraulic actuator - control surface.

192: (Q390) How would you describe this type of control system?

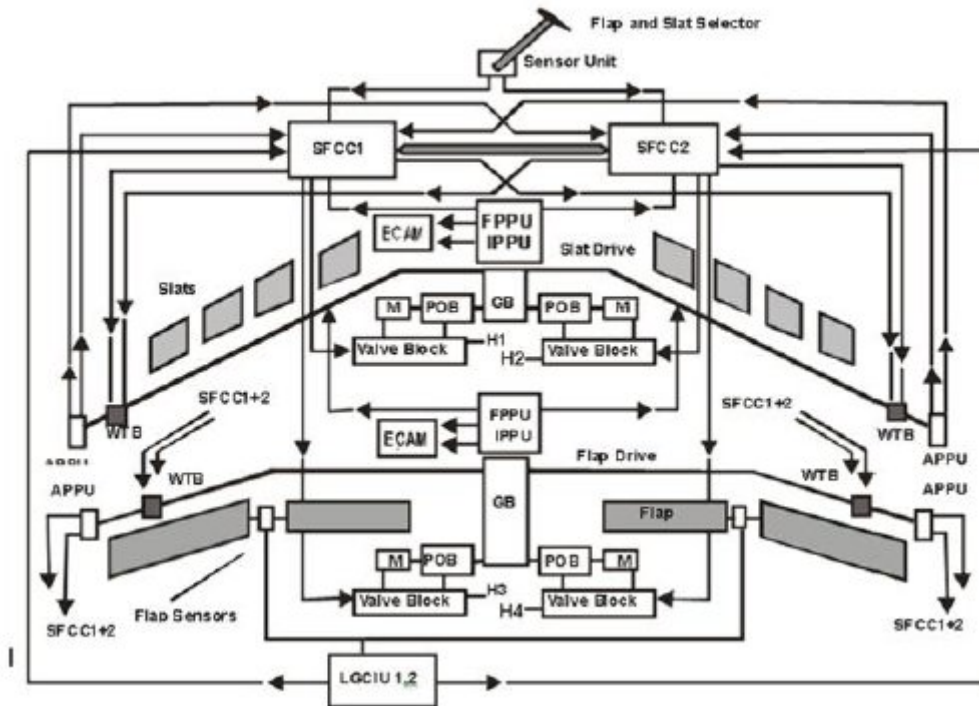

- A fly-by-wire system.
- o A responsive loop control system.
- o An auto-pilot control interface system.

193: (Q391) Which control surface(s) are used in the active load system?

- o flaps and slats.
- elevator and aileron and several spoilers.
- o only the rudder system.

194: (Q392) By which control system is the active load control accomplished?

- Electrical flight.
- o Pure mechanical flight.
- o By interruption by the pilot to activate the flight control system.

195: (Q393) Why do we need to incorporate an artificial feel system in flight controls?

- Moving a control with a servo system requires so less force input that the control may overreact by lack of feedback counterforce. We will create artificially a force feedback in relation to degrees of input and even related to speed.
  - o Because technically you cannot join the two inputs, manual and auto pilot to one control if there is not an artificial feel system to connect to them.
  - o The artificial feel in a servo mechanism is to allow to adjust the input force in relation of human force, this will keep the flying characteristics the same for every pilot. Smaller or female pilots have lesser muscle power.

196: (Q394) Why are dampers installed on the flight control surfaces command systems? Dampers will ....

- o limit the maximum deflection of the flight control surface.
- prevent flutter of the flight control surface.

- o prevent pressure shocks in the hydraulic system.

197: (Q395) Why do we have a yaw damper?

- o A yaw damper gives an extra stability (control stiffness) at the rudder during a roll. During a roll the centre of gravity of the large rudder panel shifts with an unwanted pitch down effect as result.

- o A yaw damper is needed to make an a coordinated turn. Without yaw damper the aircraft always makes a slip during a turn.

- A rate gyro measures the rate of yaw, the yaw damper will give a correction signal to the rudder to avoid the yaw, this will avoid the dutch roll.

198: (Q396) What is the main purpose of having a correct cable tension and rigging?

- A correct cable tension will give the pilot a good responsive control at all temperatures. A good rigging will give the control surface sufficient deflection in all required directions.

- o A cable must be tensioned as low as possible but still just enough to not jump out of the pulley grooves. A good rigging will give the control surface sufficient deflection in all required directions.

- o A correct cable tension will give the pilot a correct artificial feel during manoeuvres. A good rigging will give the control surface sufficient deflection in all required directions.

199: (Q397) What is the importance of temperature tables in cable rigging?

- o During rigging temperature is not relevant.

- They will compensate for the thermal expansion of the cables, so an adequate tension is obtained to operate the system at all temperatures.

- o They will compensate for the difference in thermal expansion of the aluminium fuselage.

200: (Q398) Which panel needs a balancing after a composite repair?

- o The outboard aft flap.

- The elevator tab.

- o The inboard ground spoiler.

201: (Q399) What is the purpose of a stick shaker?

- It will warn the pilot by shaking the control column that is aircraft critically close to a stall.

- o It will warn the pilot that the auto slat system is activated.

- o It will advise the pilot that he is in an active stall. The control column shakes, the pilot should immediately increase the thrust.

202: (Q400) If the control column shakes, what does it mean?

- o Indication of flutter.

- Indication that the aircraft is critically close to a stall.

- o The aircraft is outside it's manoeuvring envelope.

203: (Q401) What are the most common signals for 'automatic ground spoiler extension'?

- o Ground/flight signal and wheel spinning signal.

- Both answers are correct.

- o Throttle lever angle signal and the aircrafts speed signal.

204: (Q402) In according the EASA Part 66, spoilers operating in roll mode are considered to be....

- primary flight controls.

- o speed brakes.

o secondary flight controls.

205: (Q403) Where are the high speed ailerons installed?

- Mid wing position.
- o On the horizontal stabilizer?
- o Near the wing tip.

206: (Q404) The elevators control the movement of the aircraft on the .....

- o longitudinal axis.
- lateral axis.
- o vertical axis.

207: (Q405) The rudder controls the movement of the aircraft on the .....

- o longitudinal axis.
- o lateral axis.
- vertical axis.

208: (Q406) The aileron controls the movement of the aircraft on the .....

- o vertical axis.
- longitudinal axis.
- o lateral axis.

209: (Q407) Roll spoilers are used for ....

- o slowing down the aircraft on ground.
- attitude control.
- o slowing down the aircraft in flight.

210: (Q408) Ground spoilers are used for ....

- slowing down the aircraft on ground
- o attitude control.
- o slowing down the aircraft in flight.

211: (Q409) On an aircraft fitted with an elevator trim tab, what position must the tab be set at if the aircraft has the tendency to nose down?

- Down
- o Up
- o Neutral

212: (Q410) Which of the following control systems for the horizontal stabilizer trim has the highest priority?

- o Mach/speed trim
- o Autopilot trim
- Manual trim

213: (Q411) Why is there a balance tab installed?

- For reducing the effort to move the flight control.
- o For dynamic balancing of the flight control.
- o Where the flight controls are found rather light during initial flight-testing.

214: (Q412) Why is there an anti-balance tab installed?

- o Where the flight controls are found rather light during initial flight-testing.
- o For reducing the effort to move the flight control.
- The tab is moved to the same deflection as the flight control.

215: (Q413) In what direction moves the trim tab in relation to the flight control?

- o In the same direction as the flight control.
- o Repositioned in the mid.
- In the opposite direction of the flight control.

216: (Q414) What is the main advantage for commercial aircraft by using active load control?

- o High manoeuvrability.
- o Increased aircraft speed.
- Reduced structural loading or airframe stress.

217: (Q415) What is gust suppression?

- o A locking mechanism on the ground spoilers.
- It makes the quality of the passenger ride better in the aft portion of the fuselage.
- o It moves the elevator in the opposite direction of movement.

218: (Q416) What logic would you expect from an hydraulic operated flight control system in auto pilot function?

- Flight control computer - electrical input - hydraulic actuator - control surface.
- o Flight control computer - electrical wire - control column - electrical wire - hydraulic actuator - control surface.
- o Flight control computer - electrical wire - hydraulic motor - steel cable - control surface.

219: (Q417) What are slat track doors?

- o They close the gap in the wing when the slats are retracted.
- They close the gap in the wing leading edge when the slats are extended.
- o They can be opened to gain access to the slat tracks for maintenance.

220: (Q418) What is the purpose of a blow-back valve in the flap control system?

- o It allows the flaps to be retracted by using air loads instead hydraulic power.
- It allows the air loads to push the flaps up if the aircraft is flying too fast.
- o It prevents the flaps from being pushed back up by the air loads.

221: (Q419) If a flap asymmetry is detected during flap extension, what will happen?

- o The asymmetry protection systems retracts the flaps immediately.
- o The crew are warned of the asymmetry condition and must stop the flap operation.
- The asymmetry protection system stops the flap movement on both wings.

222: (Q420) Explain the concepts 'mach trim'.

- As an aerodynamic effect of high speed the aircraft has the tendency to pitch down. We have to correct this effect by pitch trim to keep a stable altitude.
- o As an aerodynamic effect of high speed the aircraft has the tendency to pitch up. We have to correct this effect by pitch trim to keep a stable altitude.

o As an aerodynamic effect of high speed the aircraft has the tendency to create vortex vibrations on the elevators. By trimming the stabilizers and elevators in another position we reduce this effect and still maintain the altitude.

223: (Q421) To reduce turbulence, what do the spoilers do in speed brake motion?

- o The inboard spoiler panels remain flush with the wing.
- The inboard spoiler panels raise less high than the outboards.
- o All the spoiler panels raise less high than when operated in ground spoilers mode.

224: (Q422) What happens when the pilot initiates a left turn, with spoiler augmentation?

- o Only the ailerons are used to roll the aircraft.
- The LH aileron operate up and the spoilers on the left wing raise further up.
- o The RH aileron operate down and the spoilers on the right wing raise further up..

225: (Q423) What is PFCU's manual reversion?

- o It is a system that allows the pilot to switch off the hydraulic system and fly the aircraft manually.
- It allows the pilot to operate the flight controls manually if the powered flight control unit fails.
- o It gives the pilot feedback from the flight control surface.

226: (Q424) In a manual operated control system the control surfaces are moved by ....

- cables and pushrods.
- o only pushrods.
- o only cables.

227: (Q425) A small input in a primary servo system of a hydraulic powered flying control system initiates ....

- o the same power output as the input initiated.
- a large power output.
- o a small power output.

228: (Q426) In which system should be an artificial feel system provided to the pilot?

- o Power assisted control.
- o Power cable control.
- Power operated control.

229: (Q427) What kind of information needs the stall warning computer to calculate a stall?

- o Flap/slats position, gear position, stabilizer position, thrust settings.
- Angle of attack, air speed, flap/slats position, gear position, stabilizer position.
- o Air speed, engine thrust setting.

230: (Q428) What is Mach correction?

- The reduction of the feel force at high Mach numbers.
- o The adjustment of the stabilizer position to compensate for the nose down tendency.
- o The increasing of the feel force at high Mach numbers.

231: (Q429) Which flight control is used to compensate for dutch roll.

- Rudder.
- o Ailerons.

o Elevators.

232: (Q430) Dutch roll stability can be artificially increased by a ...

- yaw damper.
- o roll damper.
- o pitch damper.

233: (Q431) What type of aerodynamic balancing system is used on modern, powered flight control surfaces?

- o Balance tabs.
- None.
- o Servo tab.

234: (Q432) What type of aerodynamic balancing is used in the rudder?



- o Trim Tab
- Horn Balance
- o Inset Hinges

235: (Q433) For the basic rigging procedure the flight control in the cockpit should set in .....

- o any position.
- neutral position and locked in this position.
- o such a way that the rigging pin can be inserted.

236: (Q434) Where is the stall warning sensor of an electric stall warning system located?

- o On the fuselage below the cockpit windows.
- o On the fuselage above the cockpit window.
- In the wing leading edge.

237: (Q435) Which of the following DO NOT actively prevent the aircraft from stalling?

- o Stick pusher.
- o Auto slats.
- Stick shaker.

238: (Q436) A stall warning system will activate:

- o When the stall occurs.
- Before the stall occurs.
- o After the stall occurs.

239: (Q490) Hydraulic power works on the basis of Pascal's law. How would you express this law? A pressure that is exercised on a fluid in a container that is completely filled and closed off,....

- o will act in downward directions.
- will act in all directions.
- o will act in side wards directions.

240: (Q491) What are the consequences when there are air bubbles in hydraulic circuit?

- o Hydraulic fluid is nearly not compressible, while air is very compressible. The pumps can't pressurize anymore.
- Hydraulic fluid is nearly not compressible, while air is very compressible. It makes the system loses efficiency.
- o It has not so much of impact on the operation of the system but it will make foam in the system and that degrades the oil much faster.

241: (Q492) What means 3000 psi?

- o 3000 pressure system indication.
- 3000 pounds per square inch.
- o 3000 particles per system inspected.

242: (Q493) What are the most important hydraulic power consumers, on modern aircraft?

- The landing gear system and the flight control system.
- o The flight control system and the engine reverser system.
- o The landing gear system and the cargo doors system.

243: (Q494) In a engine driven hydraulic circuit, where will you find the fire shut-off valve?

- o In the return line towards the reservoir.
- o In pressure line downstream of the engine driven pump.
- In the supply line from the reservoir to the engine driven pump.

244: (Q495) Which requirements do we expect from the fluid used in an aircraft hydraulic system? Low freezing point,....

- minimum change of viscosity with temperature, fire resistant.
- o anti-foam, fire resistant, odourless.
- o minimum change of viscosity with temperature, not aggressive on plastics, affordable.

245: (Q496) What is the most common used hydraulic fluid used in modern aircraft?

- Skydrol
- o Hydrofluid
- o Lokoil avio

246: (Q497) Name some basic functions of the hydraulic reservoir.

- o Provide continuous fluid for the pumps, provide fluid cooling.
- Provide continuous fluid of the pumps, allow fluid level variations, provide a system fluid reserve.
- o Provide possibility to stop the fluid to the pumps in case of fire, allow fluid level variations, provide a system fluid reserve.

247: (Q498) Which method can be used to pressurize a hydraulic reservoir?

- o Water column provides pushes on a press plate inside the reservoir. Zero maintenance system.
- Pneumatic pressure, coming from the pneumatic system (engines or APU).
- o A heating element.

248: (Q499) How would you describe an accumulator in hydraulic system?

- o An accumulator is a separate reservoir to store reserve or overflow fluid. This fluid will give some boost pressure in the system.
- An accumulator is a component where you can store energy. In a hydraulic system it is mostly a cylinder with two chambers where one will store a pressurized gas.
- o An accumulator is a component where emergency energy is stored. It contains pressurized gas . It has to be refilled each time prior to flight.

249: (Q500) What should you do first before servicing an accumulator?

- System pressure must always be removed before you can check or service a hydraulic accumulator.
- o Make sure the hydraulic system reservoir is full before you make a check or servicing of a hydraulic accumulator.
- o System pressure must always be set before you can check or service a hydraulic accumulator.

250: (Q501) Where are the main hydraulic pumps installed in an aircraft?

- o The main pumps are usually installed in the wheel wells.
- o The main hydraulic pumps are usually installed in the pylon and driven by bleed air from the pneumatic system.
- The main pumps are usually installed on the engine gear box.

251: (Q502) What kind of hydraulic pumps are normally fitted on the engine gearbox?

- Variable displacement, constant pressure, multi piston type pumps.
- o Constant displacement, variable pressure, multi piston type pumps.
- o Centrifugal pump.

252: (Q503) Explain the function of a PTU.

- o A Power Transfer Unit will transfer pressure to recover pressure between landing gear systems and flight control systems.
- o A Pressure Transport Unit will boost up the pressure to serve the tail flight controls.
- A Power Transfer Unit. This unit will transfer hydraulic pressure from one system to another (separated) system without fluid transfer.

253: (Q504) What is the name of this unit?

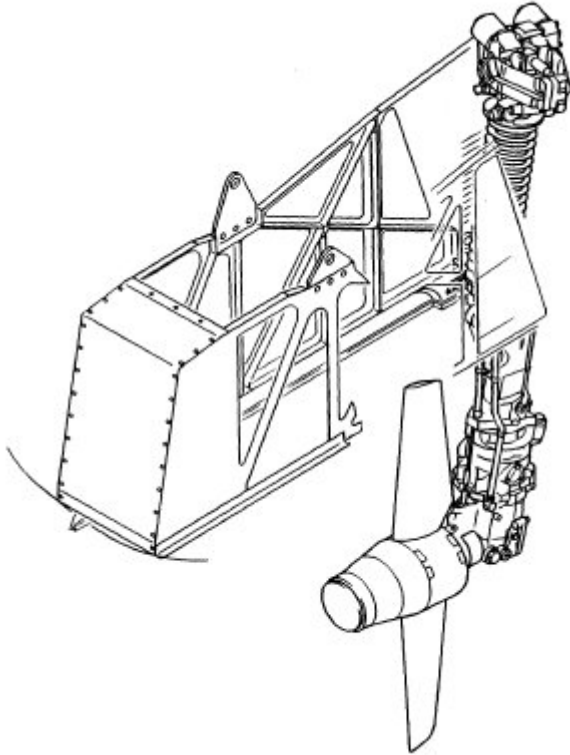

- o RAT, rotary blade ejection jack. Will eject automatically as backup when the APU fails.
- o RAM, rotary air motor. Backup system for the pneumatic system.
- RAT, ram air turbine. When extended in emergency, the turbine can drive a generator and/or hydraulic pump.

254: (Q505) Why do we need filters in a hydraulic system?

- A filter is needed to protect the system from dirt and metal particles.
- o A filter will keep dirt out of the system but the size of the opening in the wire gauze regulates mainly the flow inside the system.
- o A filter is used mainly for inspections. It will tell us the degradation of the oil quality and when to change it.

255: (Q506) What is a by-pass filter? It is a filter....

- unit with a relief valve that will open if the delta pressure over the filter exceeds a limit.
- o type with internal small vortex-vanes.
- o unit with a sensor that activates an alarm in the cockpit when the filter gets clogged.

256: (Q507) How can you recognize a by-pass type filter?

- o Physically you can't see the difference. You have to consult the manual.
- o You have to remove the filter bowl to see the difference.
- They nearly always equipped with a pop-out indicator, or an electrical switch to activate a cockpit alarm.

257: (Q508) What is a pressure relief valve? It is a unit that protects....

- o failure of other components due to over pressure. It will release the overpressure in that line section and redirect the pressure to the inlet of that unit or valve.

- o the complete system for overpressure. It will release the overpressure and drain it.
- failure of other components due to over pressure. It will release the overpressure in that line section and dump it into the return line.

258: (Q509) Why do we use priority valves?

- o Priority valves makes sure that the pressure consumers are served in the correct priority. Slats, ailerons, elevators, rudder, flaps, gears. If there is a simultaneous demand the lesser system has to wait.
- If the pressure demand is higher than the pumps can deliver, priority valves will first feed the most important system and lock out temporarily the others.
- o If the pressure supply is higher than the demand, the pumps deliver an over-press, priority valves will dump this over-press back to the reservoir.

259: (Q510) How can the pilot observe the hydraulic reservoir quantity?

- The reservoir has a floating device connect with a transmitter. This will give a direct reading capability on the reservoir and send a signal to a cockpit instrument if power is on the aircraft.
- o The reservoir has a floating device connected with a transmitter. This will give a direct reading capability on the reservoir and send a signal to a cockpit instrument even without power on the aircraft.
- o Look at the reading glass during a pre-flight inspection.

260: (Q511) What is the advantage of a powerpack compared to a normal hydraulic system? It is a....

- o self-contained system that does not require electrical power from the main electrical system.
- o more powerful system.
- self-contained system requiring no supply from the main hydraulic system.

261: (Q512) Which fluid goes through the hydraulic heat exchangers inside the main fuel tanks?

- o Pump return fluid.
- Pump case drain fluid.
- o Pump supply fluid.

262: (Q513) Which type of hydraulic system is shown?

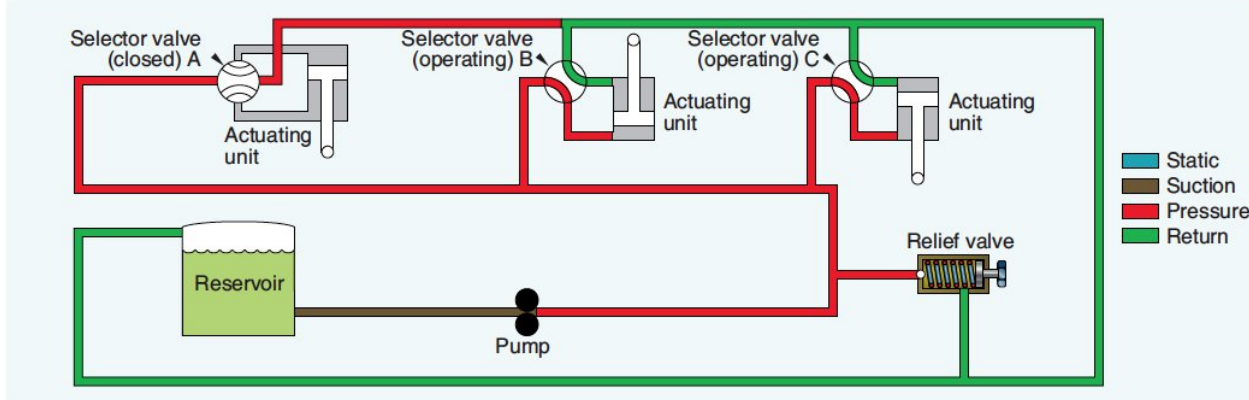

- Closed centre hydraulic system.
- o Open centre hydraulic system.
- o Multi pump hydraulic system.

263: (Q514) What defines a good hydraulic fluid?

- o A high viscosity.

- o A low flash point.
- A high fire point.

264: (Q515) What can prevent foaming of the hydraulic fluid in a reservoir at an altitude higher than 20,000 feet?

- o A integral reservoir.
- o A reservoir with a piston to separate the air from the oil.
- Pressurize the reservoir.

265: (Q516) What is a function of a hydraulic accumulator?

- o Store (pressurized) hydraulic fluid in case of a leak.
- o To use hydraulic pressure to generate electrical power.
- To absorb fluctuations in hydraulic pressure,

266: (Q517) When does automatic deployment of the hydraulic ram air turbine occur?

- o Both engines OFF - Aircraft in the air.
- o Hydraulic system pressure at ZERO - Airspeed more than 200 knots.
- Both engines OFF - Aircraft in the air - Airspeed more than 80 knots.

267: (Q518) What type of pump is shown in the figure below?

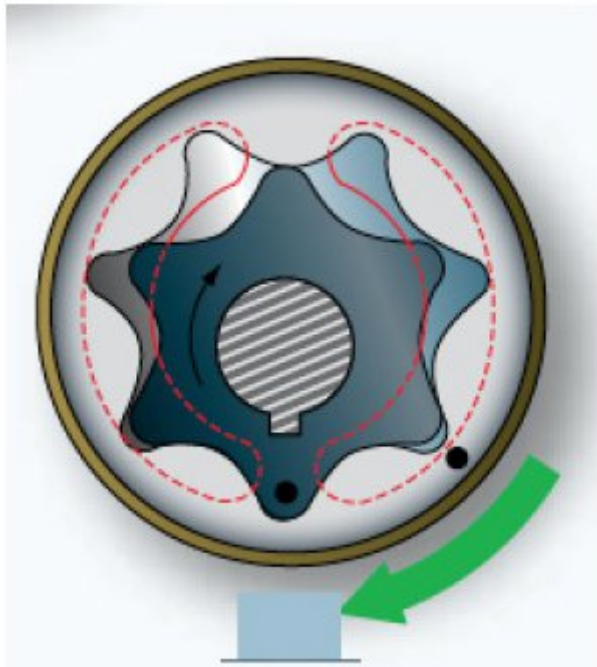

- o Hand pump
- Ge-rotor pump
- o Gear pump

268: (Q519) What is the name of the hydraulic filter located in the pump supply line from the reservoir?

- o A micron filter.
- o A return filter.
- A low pressure filter.

269: (Q520) What prevents nuisance blockage warnings of a filter at cold temperatures?

- o A thermal bypass valve on the filter.
- o A manual reset switch on the flight deck.
- A thermal lockout on the blockage indicator.

270: (Q521) What is the function of a blockage indicator?

- o It shows that the filter is bypassed.
- It shows that the filter is blocked.
- o It shows that the filters is installed incorrectly.

271: (Q522) What monitors hydraulic pump pressure?

- o They are not monitored.
- o Pressure sensors.
- Pressure switches.

272: (Q523) What is the safety device called that cuts off the hydraulic flow after a certain amount of fluid has passed through it?

- Hydraulic fuse.
- o A throttling valve.
- o A check valve.

273: (Q524) What does the dotted arrow (the arrow pointing to the right) mean in the figure?

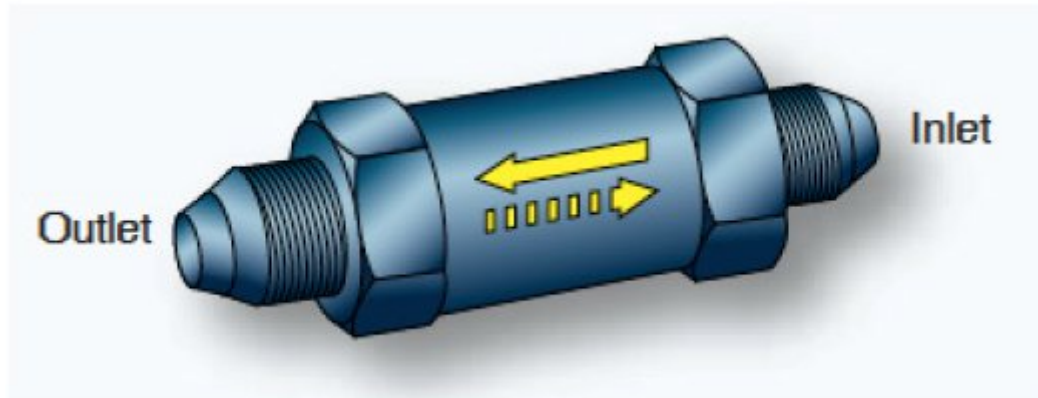

- The direction of restricted flow.
- o The direction of free flow.
- o The direction in which to install the valve (arrow pointing up).

274: (Q525) Which component in a hydraulic system cannot be tested with a hydraulic cart (or Mule)?

- Pumps.
- o Landing gear.
- o Pressure sensors.

275: (Q526) Which filter is generally cleanable and reusable?

- Wire wound filter.
- o Paper filter.
- o No filter is cleanable or reusable.

276: (Q527) If a filter is installed after the hydraulic reservoir in the pump supply line, this is a .....

- low pressure filter.
- o suction filter.
- o high pressure filter.

277: (Q528) If a filter is installed after the pump in the pressure line, this is a .....

- high pressure filter.
- o return filter.
- o low pressure filter.

278: (Q529) What are the conditions for ice to be formed on a surface? Ice will be formed....

- o when the air humidity in %  $\times$  surface temperature is below 1,472°C (Example: 65% humidity  $\times$  2 °C surface temp = 1,3°C is risk of icing).
- on a surface when humid air encounters a surface and both air and surface are below freezing temperature.
- o from the moment that the algebraic sum of the air and the surface temperature is below freezing temperature.

279: (Q530) What are super cooled water droplets?

- o These droplets formed by water with a very high Ph value (acid). These impurities make it very difficult to switch over the icing state.
- o These are water droplets near 0°C formed at a low atmospheric pressure. These droplets can grow double in size, physically impossible at sea level pressure.
- These are water droplets in liquid form but below freezing temperature. On impact with a cold soaked surface, like the ground or an aircraft fuselage, they instantly form ice crystals.

280: (Q531) On older aircraft, how can the pilot detect ice formation on his aircraft?

- o Just by visual aids. Wing leading edge lights or an ice detector sticking out between the two front windows.
- o An experienced pilot will immediately feel in on how the aircraft reacts on steering inputs.
- When his window becomes foggy.

281: (Q532) Explain the functioning of a thermal heated wing Leading Edge (LE) system.

- The hollow wing LE is fitted with a heated air duct. The forward face of this duct has a series of holes blowing hot air inside the LE cavity.
- o Via the wing LE anti-ice valve, hot air is blown inside the hollow wing LE cavity. The pressure regulating valve will maintain the pressure to 45psi which will keep the heat in the LE cavity.
- o The hollow wing LE is fitted with a thick walled copper duct. Inside this duct are electrical elements. When the system is on the heating energy will be radiated inside the LE cavity.

282: (Q533) Concerning engine anti-icing. Which statement is true?

- o Hot fluid from the hydraulic system is used to heat the nose cowl leading-edge.
- o Hot engine oil is used to heat the nose cowl leading edge.
- Hot air from the engine compressor is used to heat the nose cowl leading-edge.

283: (Q534) Why do the pitot probes need to be heated?

- o All protrusions on the fuselage will accumulate ice. A ice blocked pitot tube will register a too high airspeed which can lead to fatal accidents.

o Protruding items in the forward section can accumulate ice. A with ice blocked pitot tube will register an incorrect angle of attack.

• Protruding items in the nose area of the fuselage will accumulate ice. A with ice block pitot tube will register a too low airspeed.

284: (Q535) How can the pilot monitor the good functioning of the pitot heating?

o The pilot has no real indication. He can see that he selected the switch to on.

o Since the pitot consumes a lot of energy, the pilot can see the jumpy increase on his ampere meter when the pitot heating is switched on.

• A current monitoring circuit will activate a warning light when there is no current flow through the heating element.

285: (Q536) In the water and waste system which heater will switch over to high power when the aircraft is in flight?

o The heating gasket of the forward toilet servicing connection.

o The ribbon heaters around the water feed lines from the water tank to the forward galley.

• The water drain mast.

286: (Q537) What is a de-icing mat?

o Electrical elements around a duct inside the wing leading edge to warm up the duct air.

• Electrical heating elements embedded into the leading edge of engine intake.

o A rubber boot on a leading edge through which intermittently pneumatic air is blown. Breaking of ice by using the flexibility of rubber.

287: (Q538) Which part of the aircraft would be described as a typical de-icing element?

o De-icing boots used on a dorsal fin.

o De-icing used on the engine inlet of business jets.

• De-icing boots used on the wing and stabilizer leading edge of a propeller aircraft.

288: (Q539) Except for functional test, which system should be used only on the ground?

o Engine anti-ice system.

o Thermal system.

• Wing anti-icing system.

289: (Q540) On an aircraft where is 'rain repellent' used?

o A product to polish the cabin windows.

o On all the cockpit front and side windows.

• Only on the cockpit front windows.

290: (Q541) The can of the rain repellent system is....

o un-pressurized.

• pressurized.

o an open line and spread out by air speed.

291: (Q542) When should the rain repellent container be replaced?

o When the yellow float placard REFILL is visible.

o When the pointer moves into the yellow band.

• Both answers are correct.

292: (Q543) What precaution should be taken by using the chemical rain repellent?

- o It is only allowed to spray it on a dry windshield.
- o It is to use only on the ground for better visibility.
- It is only allowed to spray it on a wet windshield.

293: (Q544) Why does each pilot has his own wiper control switch?

- o Since the windows each have another relative angle versus the airstream (and so rain) one side will always receive considerable more water then the other.
- o So they can select each a different wiper speed for their own visibility comfort.
- For system redundancy in case of failure.

294: (Q545) Why are acrylic windows coated with wax?

- o To protect the window for erosion.
- o To give the window a shiny look. It also works as a sun reflector for the heat.
- This coating will let the rain makes bigger droplets and so blown away much easier by the airstream.

295: (Q546) Which spoilers on the wing will lift more, when the speed brake lever is engaged?

- Outboard spoilers.
- o Inboard spoilers.
- o All spoilers on the wing lift symmetrical.

296: (Q547) Which of the following is a visual ice detector?

- Hot rod ice detector.
- o Vibrating rod ice detector.
- o Radioactive ice detector.

297: (Q548) Which type of ice poses the biggest threat to the safety of an aircraft?

- o Dry Ice
- Clear Ice
- o Gleam Ice

298: (Q549) The operation of the serrated rotor ice detector is based on which principle?

- Increased torque load on the electric drive motor when covered with ice.
- o Ultrasonic vibration of the ice sensing element.
- o Blockage of small moves resulting a change in ram air pressure on a diaphragm.

299: (Q550) Engine anti-ice systems are powered by:

- o Electrical heating mats.
- o Pneumatic bleed air.
- Bleed air extracted from the on-side engine.

300: (Q551) What type of valve is the engine anti-ice valve?

- Pressure regulating and shut off valve.
- o Pressure regulation valve.
- o Shut-off valve.

301: (Q552) Which system prevents ice formation?

- o Defogging system.
- Anti-ice system.
- o De-icing system.

302: (Q553) Electrical ice protecting systems can be used for....

- o De-icing only.
- de-icing as well as anti-icing.
- o Anti-icing only.

303: (Q554) Which system is used only for de-icing an air-intake of a turbo propeller aircraft?

- Pneumatic or mechanical.
- o Electrical.
- o Hot bleed air.

304: (Q555) Which system removes ice formation?

- o Defogging system.
- De-icing system.
- o Anti-ice system.

305: (Q556) After inadvertently applying rain repellent, you must....

- immediately wash the windscreen.
- o immediately operate the windscreen wipers.
- o the rain repellent dry before washing the windscreen.

306: (Q557) Rain repellent is stored in:

- o An unpressurised canister.
- A disposable canister.
- o A rechargeable pressurised tank.

307: (Q558) Rain repellent is normally used:

- In combination with windscreen wipers at low airspeeds and heavy rain.
- o In combination with windscreen wipers at high altitudes and light rain.
- o Instead of windscreen wipers at low altitudes and heavy rain.

308: (Q559) Which of the following statements is true?

- o Drainmasts heaters can be controlled from the flight deck.
- o Drainmasts are NOT heated on the ground.
- Drainmast heaters go to a higher setting when in flight.

309: (Q560) Air data probes are ....

- o anti-iced with bleed air.
- electrical heated.
- o de-iced with pneumatic air.

310: (Q561) To prevent overheating from the drain lines on ground ....

- o drain lines should be covered with special protection covers.
- the circuit breakers must be pulled.
- o drain lines electrical connector should be disconnected.

311: (Q562) How does a pneumatic rain removal system work?

- o By using bleed air to operate pneumatic actuators to move the wiper blades.
- By blowing high pressure bleed air over the windscreen.
- o By heating the windscreen with hot bleed air.

312: (Q563) What is the purpose of the parallel motion device on a wiper system?

- o Ensures the blade moves in normal arc.
- o Ensures the blade maintains contact with the screen.
- Ensures the blade remains parallel with the screen.

313: (Q564) Why must you always wet the windscreen before operating the wipers?

- o To prevent unnecessary wear of the wiper blades.
- To prevent damage to the windscreen.
- o To prevent wear on the drive mechanism of the wipers.

314: (Q565) What is the function of the tapered metering pin inside the shock absorber?

- During gear compression the pin will gradually narrow the section, so the oil flowing from one chamber to another will become more difficult, making the damping harder.
- o The pin will gear retraction, the pin will be pulled away so the nitrogen and oil can change from chamber. Nitrogen on highest point.
- o It must regulate a constant flow of oil from the lower chamber to the upper chamber during compression.

315: (Q566) What is the function of the rebound check valve inside the shock absorber?

- o It gradually stop the flow between the two chambers when the gear is coming near the fully compressed condition.
- o It will open to full flow between two chambers, when the inner cylinder moves in the extend direction.
- It will limit the flow between chambers more when the inner cylinder moves in the extend direction. .

316: (Q567) When talking about landing gear, what do we mean with track?

- o Is the distance between the most aft wheel to the nose wheel.
- o Is the route followed by the nose and main wheel performing the smallest turning circle.
- Is the distance between the far right to far left wheel.

317: (Q568) When talking about landing gear, what do we mean with wheel base?

- o Is the distance between two wheels on the main gear.
- Is the distance between the nose wheel axle and the center of the boogie of the main landing gear.
- o Is the average ground surface covered by all the wheels. (factor depending on number and size of wheels)

318: (Q569) What will determine how many wheels are installed on an aircraft?

- o The maximum aircraft landing speed.
- o The number of wheels are limited by the size of the wheel wells.
- Each wheel can carry a maximum load. The mass of the fully loaded aircraft / load factor of the wheel = minimum number of wheels needed.

319: (Q570) When talking about landing gear, what do we mean with bogie tilt?

- o Is the angle the bogie will make in relation to the strut at touchdown.
- Is the angle of the bogie related to the vertical landing gear strut so it will fit into the wheel well.
- o Is the angle which the bogie will make in relation to the strut at take-off rotation.

320: (Q571) When talking about the nose landing gear, what do we mean with centring cams?

- Is a double V cam that will, centre the inner cylinder to the outer cylinder at gear extension so the steering wheels are safely centred to enter the wheel well.
- o Is the name for the centre bolt that connects the upper and lower torsion link.
- o Is the typical steering centring system that steer the wheel straight forward when the pilot releases the steering wheel.

321: (Q572) What happens when we set the landing gear lever in the 'OFF' position?

- o It will inhibit the emergency extension.
- o This is a safety position for maintenance purposes.
- All the landing gear retraction/extension components are set to return line.

322: (Q573) Explain the functioning of an mechanical operated sequence valve in the landing gear retraction/extension system?

- o The sequence valve will mechanically close his own sleeve from the pressure line when his function is terminated.
- The correct positioning of one component will set the sequence valve so that the hydraulic flow is allowed to the next actuator to move.
- o The valve has so many ports as sequences required in the system. When one movement is fulfilled, the momentarily over-press in the line will se the following port under pressure.

323: (Q574) How will the gear extend in emergency?

- o By pulling on the gear emergency reset cable, the extension valve is connected to the standby hydraulic system. Once the valve is in position the standby pump is activated and gear extended.
- By mechanical means the over-centre position of lock links or uplock hooks is disturbed out of position. This will free the gear, so it can fall down freely by gravity.
- o From the cockpit a cable is pulled under tension. This will engage the door switch to open. When the door is open the gear is released.

324: (Q575) What does the indication of a red landing gear warning light mean?

- The gear is still in transit and is not locked.
- o The gear is locked in down position.
- o The gear is locked in upper position.

325: (Q576) Is it possible to see a green and a red gear indication light simultaneously?

- o Yes, gear lever selected down and gear is in down transmit but the unlock hook stayed blocked in his up position.
- o No, this is under no condition possible.
- Yes, (for very short time) the gear is down and locked while the handle is selected up.

326: (Q577) What can the pilot do when he has no indication at all for a particular gear?

- He can check the gear down and lock position via a viewer. (If option installed)
- o He can consult the near/far condition of the proximity switch via the MCDU. (If option installed)

o He can pull and set the indicator circuit breaker. This will always reset the system.

327: (Q578) Why is a wheel made out of two halves?

o One reason only, money. It is a lot cheaper to make two wheel halves, then a wheel of that size in one piece.

o They only use this technique because in overhaul shops the tire can be removed or installed by robots completely automated.

- Because the tire bead wire is so rigid it is impossible to be rolled over the wheel rim edge during installation. (like a car tire is installed on the wheel)

328: (Q579) What is the purpose of the splines installed on the inner side of the wheel rim?

o They are reinforcements of the wheel rim.

- They make the connection between the wheel and the rotors of the brake unit.

o They keep the heat shields in place.

329: (Q580) Describe the function of a brake. By friction the brakes transform....

o mechanical torsion force into heat.

- kinetic energy into heat.

o dynamic energy into heat.

330: (Q581) What is the function of the anti-skid system? It will prevent skidding of the wheels by....

o releasing the brake pressure. When the wheel speed is less than 50% of the aircraft speed.

- monitoring the rate of wheel speed deceleration.

o monitoring the rate of aircraft speed deceleration.

331: (Q582) How would you describe the used profile of an underinflated tire?

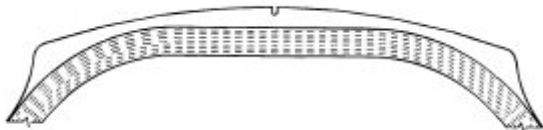

o The outboard ribs on the tire are still present while the middle rib is used.

- The middle rib is still present while the rest of the profile is used.

o The centre rib and the ribs towards the centre of the aircraft are worn while the outboard profile of the tire still is reasonably good.

332: (Q583) How would you describe the used profile of an over inflated tire?

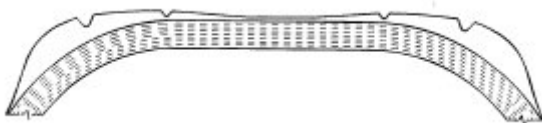

o The outboard side edge are extremely worn while the rest of the tire profile is ok.

- The centre rib are used while the exterior ribs stays fairly good.

o The exterior ribs are used while the centre rib is good.

333: (Q584) How does the pilot usually steer the aircraft (at low speed) on ground? (commercial jets)

- o By moving the rudder pedals.
- By mean of a steering wheel or tiller.
- o By alternate braking.

334: (Q585) What power source will turn the steering wheels? (large commercial jets)

- o Electrical power.
- o Pilot muscle power, transmission via cables.
- Hydraulic power.

335: (Q586) What is 'wheel track'?

- o The horizontal distance between main and nose landing gear.
- The distance between left and right main landing gear.
- o The amount of degrees the aircraft deviates from the straight ahead track while taxing.

336: (Q587) What is the function of the oil in a gas/oil shock absorber?

- o Absorbs heat.
- o Lubricates the piston.
- Controls the recoil.

337: (Q588) What is the function of the two safety bars indicated in the figure?



- They allow the landing gear to force open the door in case of a hydraulic failure.

- o They add strength to the door structure.
- o They stop the wheels from spinning after gear retraction.

338: (Q589) After an emergency landing gear extension the door will:

- o Close if hydraulic power is available.
  - Remain open.
- o Close.

339: (Q590) How is a landing gear mechanical locked down?

- o By over-centring links.
- o by lock pins.
  - By a down-lock actuator.

340: (Q591) When the landing gear selector lever is in the off position all hydraulic components are .....

- o connected with the sump line.
  - connected with the return line.
- o connected with the pressure line.

341: (Q592) A red light inside the landing gear selector lever is illuminated, this means:

- The landing gear is not in selected position.
- o The landing is up and locked.
- o The landing gear is down and locked.

342: (Q593) Which indications are shown when the landing gear is up and locked?

- o Three green lights.
- o Three red lights.
  - Nothing.

343: (Q594) In which way can sequence valves in a landing gear system be operated?

- o Hydraulic and electrical.
  - Mechanical and hydraulic.
- o Electrical and mechanical.

344: (Q595) What is a fusible plug?

- o A type of plug to quickly deflate the tyre before replacing it.
  - A type of plug which melts when the tyre gets too hot.
- o A type of valve which opens when the tyre pressure gets too high.

345: (Q596) What is the most common type of wheel bearing used?

- o Ball bearings.
  - Conical roller bearings.
- o Needle bearings.

346: (Q597) Which type of wheel rim uses tubeless tyres?

- Split hub.
- o Well-based rim.
- o Loose and detachable flange rim.

347: (Q598) What are creep indicators?

- Shows how much a tyre has moved on the rim.
- o A warning light in the cockpit to show that the aircraft has moved on the ground.
- o Shows how much a tyre has moved compared to the inner tube.

348: (Q599) Where would you find a chined tyre?

- o On large military jets main wheels.
- On the nose gear tyre.
- o On the tail gear tyre.

349: (Q600) Which of the tyres shown would require immediate replacement?



o



•



o

350: (Q601) During take-off and landing, the rudder pedals can give:

- Limited nose wheel steering commands.
- o Full nose wheel steering commands.
- o No nose wheel steering commands.

351: (Q602) What is the purpose of body gear steering?

- To reduce the wear on the tyres in sharp turns.
- o To be able to steer the aircraft if the nose gear steering fails.
- o To be able to turn more sharply.

352: (Q603) In a non-hydraulic shimmy damper, what is used to dampen the vibrations?

- o Compressed air.
- o A spring.
- A rubber piston.

353: (Q604) What is the advantage that stress sensors have over other air/ground sensing systems?

- Can measure aircraft weight.
- o More reliable.
- o Is easier to replace.

354: (Q605) A proximity sensor which is in 'target far' condition is said to be the equivalent of:

- o A failed switch.
- An open switch.
- o A closed switch.

355: (Q606) On aircraft with bogie beams (trucks), what is used to detect air/ground?

- o Weight-on-wheel switched.
- Truck tilt switches.
- o Squat switches.

356: (Q607) Which external lights are always illuminated while the aircraft is in operation?

- o Landing lights.
- Navigation lights.
- o Belly lights.

357: (Q608) The green coloured navigation light is mounted on which location?

- o Tail.
- Right side wing tip.
- o Top of the centre fuselage.

358: (Q609) When the anti-collision light is switched on by the pilot, on the ground. What does this mean for the technician?

- o Anti-collision lights are always on, as long as electrical power is supplied to the aircraft.
- o The external power can be removed.
- The engines will be started, it's a warning signal.

359: (Q610) During a flight in the night, the cockpit instruments are illuminated by:

- o Only the primary flight instruments are illuminated, dark cockpit philosophy.
- o Direct lighting
- Instrument lighting, flood lights and spot lights.

360: (Q611) How is this type of illumination called?



Flood lighting

- o Spot lighting
- o Instrument lighting

361: (Q612) Why are luminescent floor strips installed in a passenger aircraft?

- o Flood lighting is used in the cabin for the visual comfort of passengers.
- o To indicate that luggage is not allowed to be placed in the aisle.
- To guide passengers to exits in case of emergencies.

362: (Q613) Which exit sign will indicate an exit on an aircraft?



363: (Q614) Which lights can be used to detect ice build-up?

- Runway turn-off lights.
- Wing scan lights.
- Position lights.

364: (Q615) Where will you find taxi lights?

- On the nose landing gear.
- In the wing leading edges.
- In the wing root.

365: (Q616) Lights fitted with a dual filament are used as:

- Runway turn-off light and engine scan light.
- Landing light and taxi light.
- Landing light and runway turn-off light.

366: (Q617) What kind of light is used as cabin flood lighting?

- Incandescent lightbulbs.
- Spot lights
- Fluorescent tubes.

367: (Q618) Which lights are located in the passenger service units?

- Flood lights.
- Spotlights.
- Cabin emergency lights.

368: (Q619) Who controls the 'no smoking' and 'fasten seat belts' lights?

- Pilot.
- Flight attendant.
- Passenger.

369: (Q620) Which statement is true?

- Operating the internal emergency light switch only turns on the internal emergency lights.

- o When operating the external emergency light switch both internal and external lights come on.
- When the internal emergency light switch is used both internal and external emergency light come on.

370: (Q621) To ensure correct operation of the emergency lighting system, what must be done at specific maintenance intervals?

- Replace the battery pack.
- o Recharge the battery packs.
- o Replace all emergency light bulbs.

371: (Q622) The external emergency lights are used for:

- Illuminating the escape slides.
- o Illuminating the area around the aircraft to help rescue workers.
- o Identifying the entry doors to help rescue workers locate them.